

OPTIONAL

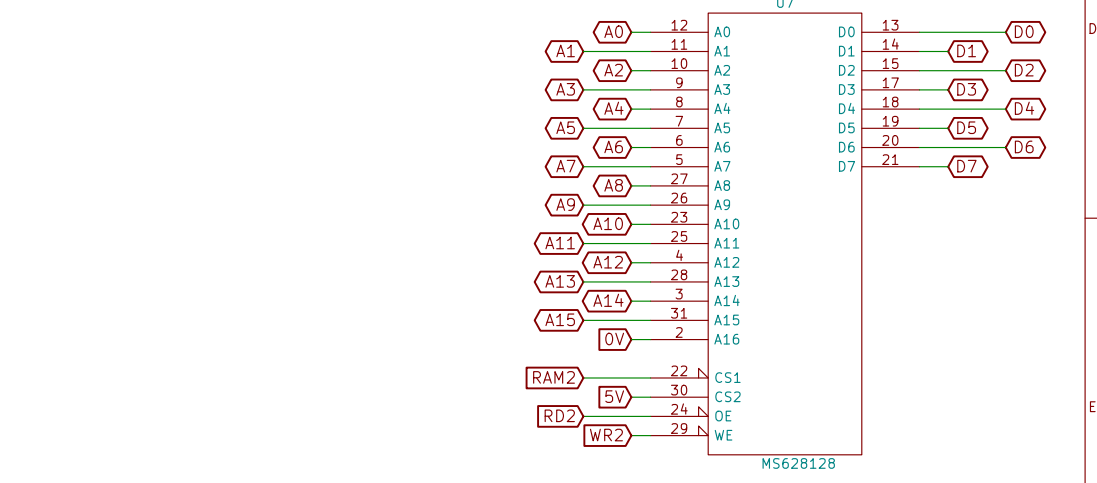
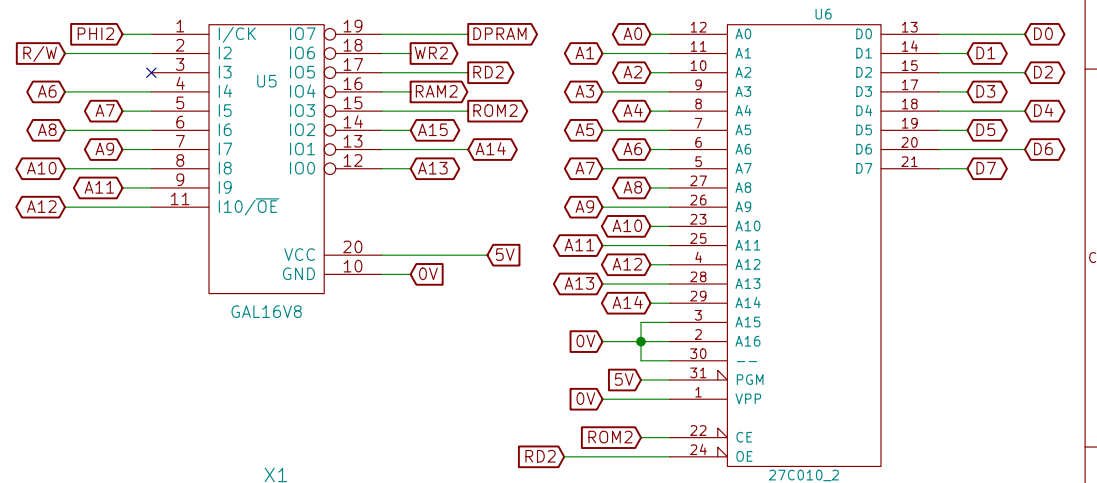
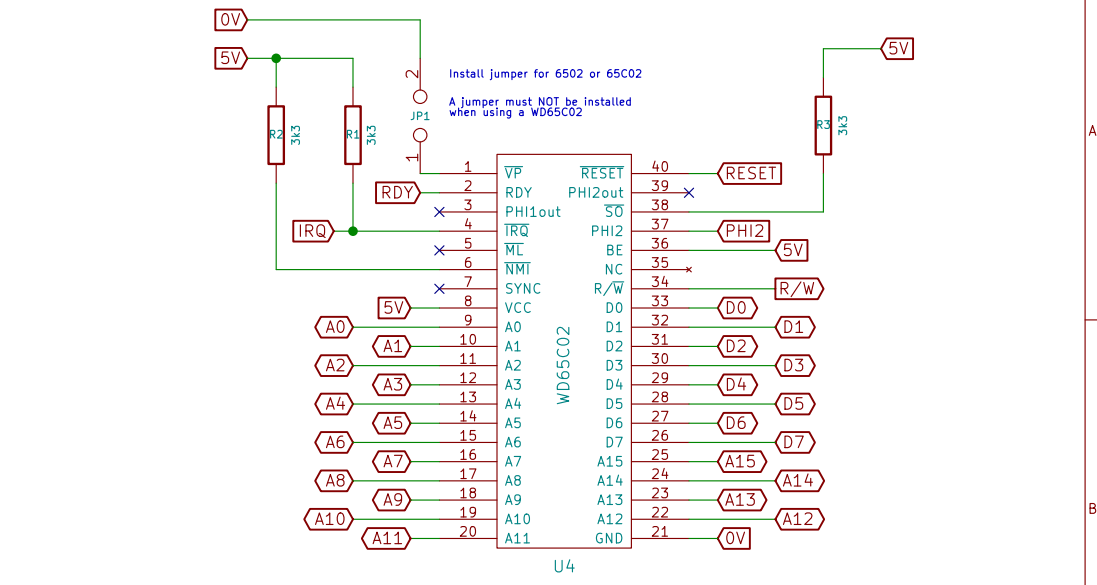
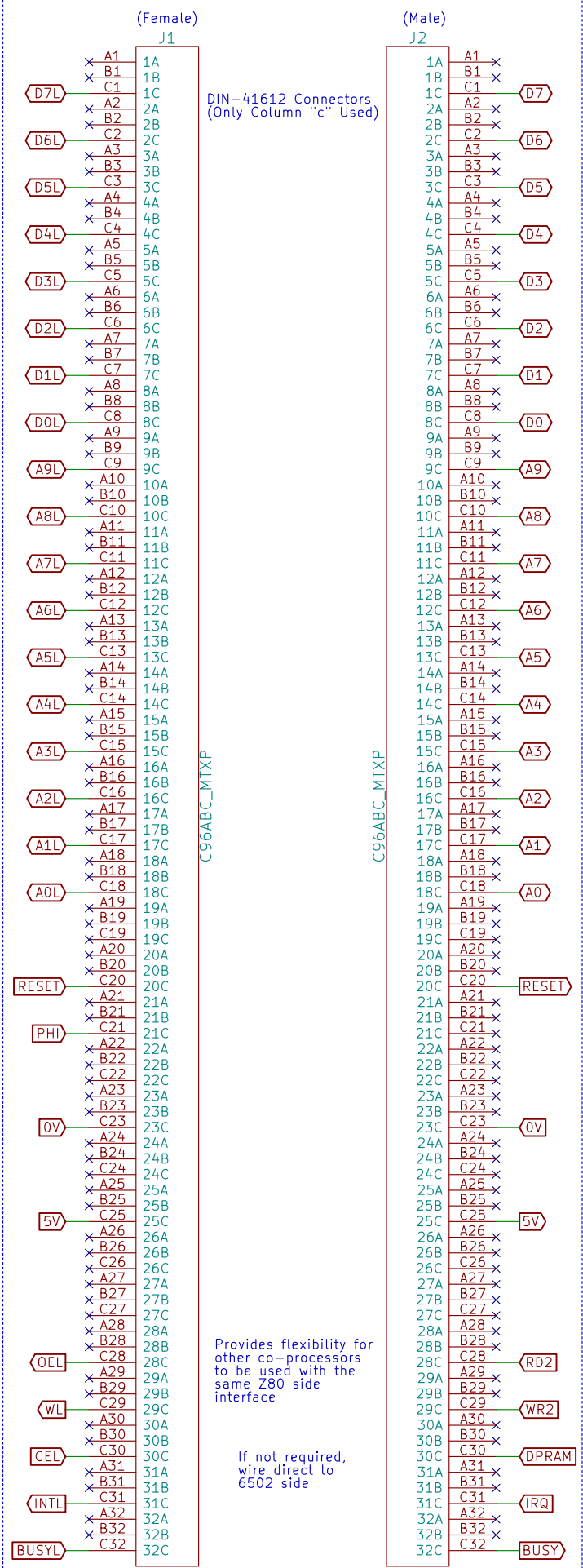

Drawn by Dave Stevenson

Designed by Martin Allcorn

Sheet: /

File: copro.sch

**Title: Memotech MTX Computer : 6502 Co-Processor**

Size: A3 Date: 2016-01-23 Rev: 1.01

KiCad E.D.A. kicad 4.0.1-stable Id: 1/1