



MITSUBISHI

5 1/4" FLEXIBLE DISK DRIVE

MODEL M4851

OEM MANUAL

TJ2-G30211 A
11/83



M4851 OEM MANUAL

1. INTRODUCTION
 - 1.1 General Description
 - 1.2 Specifications
 - 1.2.1 Performance Specs
 - 1.2.2 Functional Specs
 - 1.2.3 Physical Specs
 - 1.2.4 Environmental Specs
 - 1.2.5 Reliability Specs

2. GENERAL OPERATION
 - 2.1 System Operation
 - 2.2 Electronics
 - 2.3 Rotation Mechanism
 - 2.4 Positioning Mechanism
 - 2.5 Read/Write Heads

3. FUNCTIONAL OPERATION
 - 3.1 Power-On Sequencing
 - 3.2 Drive Selection
 - 3.3 Positioning Operation
 - 3.4 Side Selection
 - 3.5 Read Operations
 - 3.6 Write Operations
 - 3.7 Disk Insertion
 - 3.8 Disk Removal

4. ELECTRICAL INTERFACE
 - 4.1 Signal Interface
 - 4.1.1 Cabling Method and Input Terminations
 - 4.1.2 Line Drives and Receivers
 - 4.1.3 Input Signal Lines
 - 4.1.4 Output Signal Lines
 - 4.2 Power Interface
 - 4.2.1 DC Power

5. PHYSICAL INTERFACE
 - 5.1 Signal Connector
 - 5.2 DC Power Connector
 - 5.3 Frame Ground Connector



- 5.4 Interface Connector Location

- 6.1 Installation Orientation
- 6.2 Drive Dimensions

- 7. USER OPTIONS
 - 7.1 DS0 ... DS3
 - 7.2 MX
 - 7.3 HS
 - 7.4 HM
 - 7.5 HC
 - 7.6 MM
 - 7.7 MS
 - 7.8 H-1
 - 7.9 H-2
 - 7.10 H-3
 - 7.11 R-2
 - 7.12 R-3
 - 7.13 R-4
 - 7.14 MC
 - 7.15 RD-RS
 - 7.16 DI
 - 7.17 Write Protect Inversion
 - 7.18 Terminations
 - 7.19 Options Timing Examples
 - 7.20 Summary Table

- 8. RECORDING FORMAT
 - 8.1 Recording Encoding
 - 8.1.1 FM
 - 8.1.2 MFPM
 - 8.1.3 MMFM
 - 8.2 Track Format
 - 8.3 Error Detection and Correction
 - 8.3.1 Write Errors
 - 8.3.2 Read Errors

- 9. SHIPPING
 - 9.1 Shipping Damage
 - 9.2 Re-Shipping



1.0 INTRODUCTION

The Mitsubishi M4851 is a high-performance, double-sided, double bit and double track density flexible disk drive using a standard 5.25-inch diskette, that provides maximum customer satisfaction with high reliability and long service life.

- Main Features -

- o Only half the height of a standard mini-floppy drive.
- o Has an unformatted capacity of one-half megabyte.
- o Includes a diskette ejector for easy diskette removal.
- o A new circular gimbal spring in the read/write head suspension mechanism greatly improves medium tracking performance.
- o The steel band, flat stepping motor drive system for positioning achieves the best intertrack access time in its class: just 6 ms.
- o The maintenance-free, DC, brushless, direct-drive motor obviates the belt replacement necessary for conventional counterparts.
- o Excellent media interchangeability, wide off-track window time margin, and high performance are maintained over wide ambient temperature and relative humidity ranges.
- o The high-torque spindle motor permits control by switching on and off either the motor (starting time 250 ms) or the head load solenoid (loading time less than 50 ms).
- o Dynamic clamping insures correct disk seating with easy disk insertion.



1.1 GENERAL DESCRIPTION

- The M4851 Flexible Disk Drive is a twin-head, double-sided magnetic disk drive with an unformatted memory capacity of one-half megabyte for double-density recordings.
- The M4851 reads and writes 5.25-inch, double-sided diskettes in double-density format.
- The M4851 employs the unique Mitsubishi circular gimbal spring for holding and loading the magnetic heads to assure soft, steady contact with the medium. This means excellent read/write operation and a long service life for the medium. One of the outstanding features of this mechanism is reduction of the effects of jacket deformation and thickness variations, thereby stabilizing read/write performance.

1.2 SPECIFICATIONS

1.2.1 Performance specifications (Table 1-1)

Double Density	
Memory capacity	
Unformatted	
Disk	500 kilobytes
Per surface	250 kilobytes
Per track	6.25 kilobytes
Formatted	
Disk	327.7 kilobytes
Per surface	163.8 kilobytes
Per track	4096 bytes = 256 bytes x 16 sectors
Transfer rate	250 kilobits/second
Average latency time	100 mS
Access time	
Track to track	6 mS maximum (unsettled)
Average	103 mS (including settling time)
Settling time	25 mS maximum
Head loading time	50 mS maximum (including settling)
Motor starting time	250 mS maximum

Table 1-1 Performance Specifications



1.2.2 Functional specifications (Table 1-2)

	Double Density
Recording density	5922, bits per inch, maximum
Magnetic flux inversion density	5922 FCI, maximum
Encoding method	MFM
Track density	48 tracks per inch
Number of cylinders	40
Number of tracks	80
Number of heads	2
Rotation speed	300 RPM
Rotation period	200 mSec
Index	1
Media	Double-sided 48 TPI, double density, standard 5.25-inches diskette

Table 1-2 Functional Specifications



1.2.3 Physical specifications (Table 1-3)

DC power requirements	
+5 V	+5 V 5%, 0.5 A typical (seeking)
+12 V	+12 V 5%, 0.5 A typical (seeking)
Heat dissipation	8.5 watts typical, seeking
	5.0 watts typical, reading in standby mode
	4.0 watts typical motor off

Physical dimensions	(Except for front panel)
Height	1.62 in (41 mm)
Width	5.75 in (146 mm)
Depth	8 in (203.2 mm)
Front panel dimensions	
Height	1.65 in (42.0 mm)
Width	5.83 in (148.0 mm)
Weight	2.9 lbs (1.3 kg)

Table 1-3 Physical Specifications



1.2.4 Environmental Specifications (Table 1-4)

Operating environmental
conditions

Ambient temperature	5 to 46 Deg. C (41 F to 115 F)
Relative humidity	20% to 80% (Maximum wet bulb temperature: 29 C (85 F))
Shock	2.5 G Max (20 mSec)
Vibration	0.25 G Max (5-200 Hz.)
Altitude	-300 to 3000 meters

Non-operating environmental
conditions

Ambient temperature	-20 to 51 Deg. C (-4 F to 125 F)
Relative humidity	5% to 95%
Shock	30 G Max (20 mSec)
Vibration	3.0 G Max (5-200 Hz.)
Altitude	-300 to 3000 meters

Transportation environment
conditions (max 72 hours)

Ambient temperature	-40 to 62 Deg. C (-40 to 144 Deg. F)
Relative Humidity	1% to 95%, non-condensing

Table 1-4 Environmental Specifications



1.2.5 Reliability specifications (Table 1-5)

MTBF	10,000 POH minimum
MTTR	30 minutes
Unit life	5 years or 20,000 energized hours, whichever comes first
Media life	
Insertion	3×10^4 or more
Rotational life	3.5×10^6 pass/track or more
Tap-tap	10^5 on the same spot of a track
Error rate	
Soft read error	10^{-9} bit
Hard read error	10^{-12} bit
Seek error	10^{-6} seek

Table 1-5 Reliability Specifications

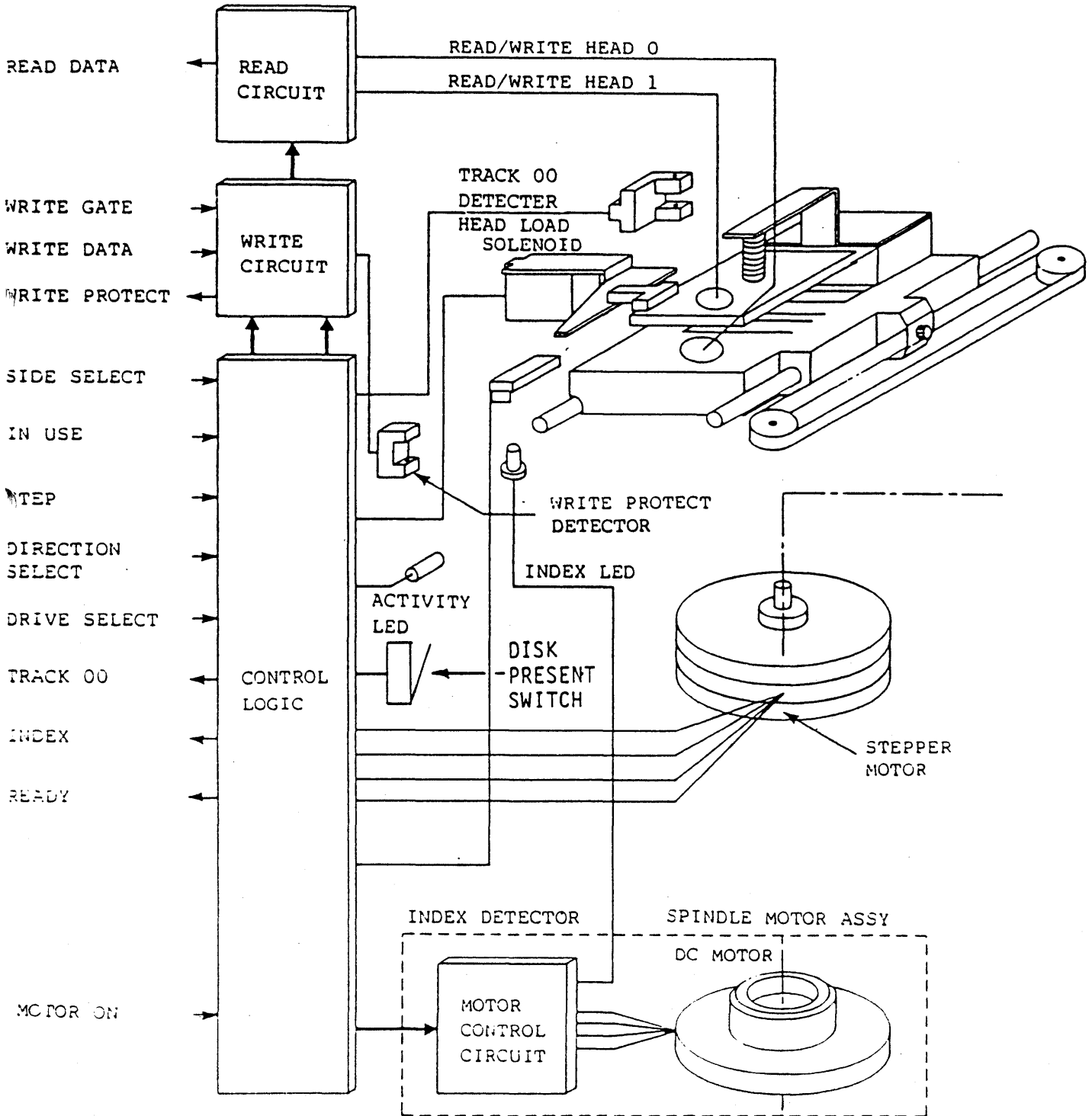

Figure 2-1 M4851 Functional Diagram



2.0 GENERAL OPERATION

2.1 System Operation

The M4851 Flexible Disk Drive consists of a medium rotating mechanism, two read/write heads, an actuator to position the read/write heads on tracks, a solenoid to load the read/write heads on the medium, electronic circuits to read and write data, and to drive these components.

The rotation mechanism clamps the medium inserted into the drive to the spindle, which is directly coupled to the DC brushless motor, and rotates it at 300 rpm. The positioning actuator moves the read/write head over the desired track of the medium. Then, the head loading solenoid loads the read/write head on the medium to read or write data.

2.2 Electronic Circuits

The electronic circuits driving the individual mechanisms of the M4851 are located on a single printed-circuit board, which consists of the following circuits:

- o Line driver and receiver that exchanges signals with the host system
- o Drive selection circuit
- o Index detection circuit
- o Head positioning actuator drive circuit
- o Head loading solenoid drive circuit
- o Spindle motor control circuit
- o Read/write circuit
- o Write protect circuit
- o Track 00 detection circuit
- o Drive ready detection circuit
- o Head selection circuit
- o In use and panel indicator LED drive circuit



2.3 Rotation Mechanism

The diskette rotation mechanism uses a DC brushless direct-drive motor to directly rotate the spindle at 300 RPM.

2.4 Positioning Mechanism

The positioning mechanism is a high-performance steel band type.

The head carriage assembly is fastened to the steel band which in turn is secured around the capstan of a two-phase hybrid stepping motor; a 3.6 turn of the stepping motor moves the read/write head one track in the designated direction, thus positioning the read/write head.

This drive system is temperature compensated to minimize read/write head deviations from the disk tracks caused by ambient temperature change.

2.5 Read/Write Heads

The read/write heads use MnZn magnetic ferrite.

Each read/write head has three ferrite cores, consisting of a read/write core and erase cores on both sides of the read/write core to erase the space between tracks (tunnel erase).

The two read/write heads, which are located face-to-face with the disk between them, are mounted on compliant, circular gimbal springs so that the heads track the disk with good contact to enable maximum reproduction of the signals from the disk. The high surface tracking ability of the circular gimbal keeps the disk free of stress, and thus improves diskette life.



3.0 FUNCTIONAL OPERATION

3.1 Power On Sequencing

No read/write operation may be performed for a period of 200 msec after the application of DC power to the drive.

The read/write head may be positioned on an incorrect track after switching the DC power on, so before starting a read/write operation, perform a step out operation until a track 00 signal is detected, thus correctly positioning the head at a known position.

3.2 Drive Selection

The M4851 daisy chain cabling system permits connection of multiple drives with a single cable.

These drives are selected when the drive select lines from the controller become active. Only the drive whose drive select line is active sends and receives signals to and from the host system. The select lines on the drives must have different numbers if two or more drives are connected. If the same number is assigned, an operation error occurs due to interference among the output signals of the drives.

3.3 Positioning Operation

The seek operation which moves the read/write head to the desired track selects a direction first, inward or outward, with the polarity of the direction select signal, and moves the head with the step signal. If access to a track two or more tracks away is required, step pulses are continuously sent until the head moves to the desired track.

Head movement occurs with the trailing edge of the step pulse. Fig. 3-1 shows the operation timing.

3.4 Side One Selection

The read/write heads located on both sides of the diskette are selected by the side one select signal. When the side one select line is high, the side 0 head is selected. When it is low, the side 1 head is selected.



3.5 Read Operation

Three modes of encoding, FM, MFM, or MMFM are used for the data stored on media. FM is used for single-density recording, and MFM or MMFM for double-density recording.

The required timing for FM read operations is shown in Figs. 3-1 and 4-5. These timing specifications are necessary for accurate read operation.

A comparison of the FM and MFM encoding modes is shown in Fig. 3-2. See chapter 8 for a complete description of encoding methods.

3.6 Write Operation

Write data can be encoded by either FM, MFM, or MMFM. The M4851 has good contact stability of the read/write heads on the medium and employs high-performance read/write heads, so no precompensation is necessary for correcting the bit shift effect when writing data in the MFM mode (double density). Specifically, precompensation of 250 nSec or smaller should be used on tracks 43 and above, and none should be used on lower numbered tracks.

The required timing for write operation is shown in Fig. 4-3. See chapter 8 for a complete description of encoding methods.

3.7 Disk Insertion

The sequence of events that occur with disk insertion are:

- 1) The user inserts the disk into the drive until audible "click" is heard. This indicates that the drive ejection mechanism has received the disk.
- 2) When the disk is fully inserted into the drive, a mechanical switch is actuated, and the spindle motor starts to rotate.
- 3) The user clamps the disk on to the rotating spindle using the bridge handle. The handle is moved until an audible click is heard.
- 4) The disk starts to rotate, and the index sensor begins to detect pulses of light from the index LED.
- 5) The index pulses are detected in a minimum period of time, which switches the "current ready" and "held ready" logic to a true state. (If the disk is not properly seated, this will not occur because the index hole in the disk will never allow light to strike the precise location required to activate the photo-transistor that is the index pulse sensor.) The spindle motor is turned off.
- 6) Option jumper H-3 (or in some cases H-1) may be used with option HC to load the head on to the disk at this time. This is desirable if the user wishes to eliminate the head load and settling times associated with motor start/stop operation.

3.8 Disk Removal

To remove the disk from the drive the user depresses the front panel door flap, which releases the bridge handle. The ejector mechanism then transports the disk out of the drive into the users fingers.

This action also resets the "held ready" status to a false condition, which can be detected by having the system controller poll the drive for its status (if the R-3 option is used).

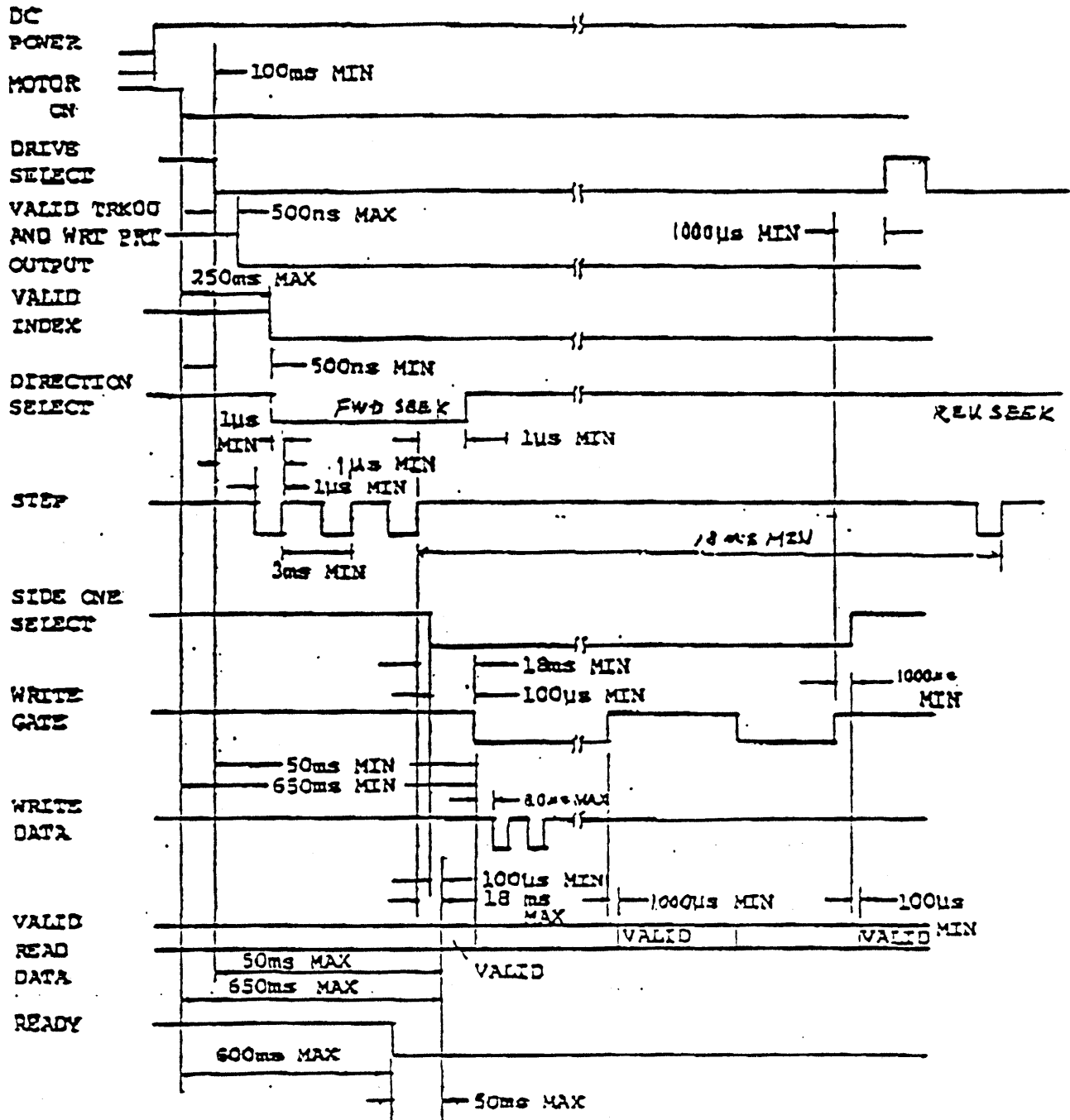

Figure 3-1 Control and Data Timing

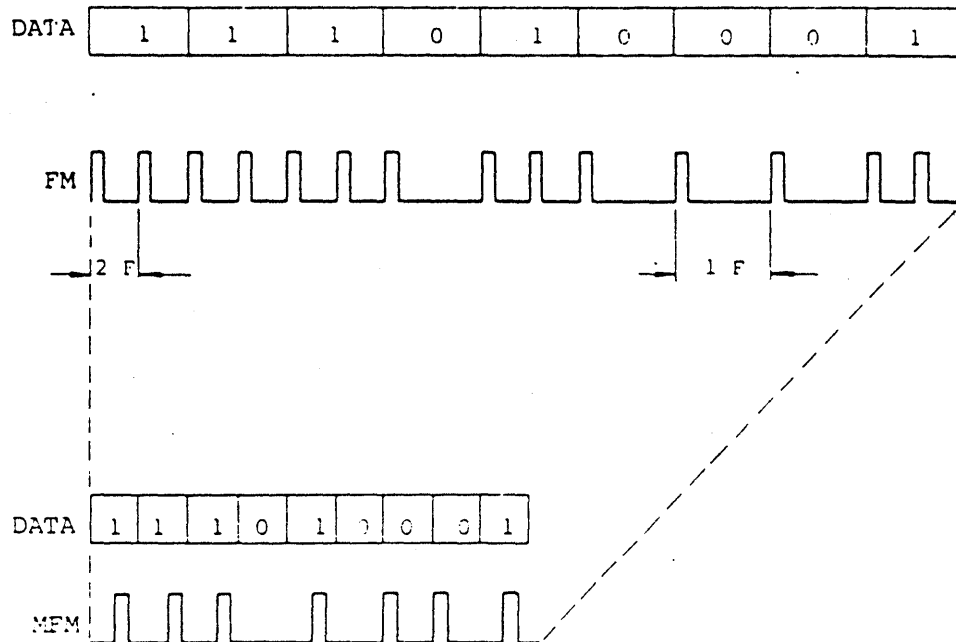

Figure 3.2 Comparison of FM and MFM encoding



4.0 ELECTRICAL INTERFACE

There are two kinds of electrical interfaces: Signal interface and DC power interface.

The signal interface sends and receives control signals and read/write data between the M4851 and the host system via the J1/P1 connector.

The DC power interface drives the spindle drive motor of the M4851, and supplies power to the electronic circuits and the stepping motor which drives the read/write head positioning mechanism via the J2/P2 connector.

The signals and pin arrangement of these two types of interfaces are shown in Tables 3-1 and 3-2.

Source voltage	Pin number
+12 V DC	1
+12 V DC return	2
+5 V DC return	3
+5 V DC	4

Table 4-1 DC Power Connector Pin Arrangement (J2/P2)



Signal	Type	Signal Pin No.	Ground/Return Pin No.
SPARE	-----	2	1
IN USE	Input	4	3
DRIVE SELECT 3	Input	6	5
INDEX	Output	8	7
DRIVE SELECT 0	Input	10	9
DRIVE SELECT 1	Input	12	11
DRIVE SELECT 2	Input	14	13
MOTOR ON	Input	16	15
DIRECTION SELECT	Input	18	17
STEP	Input	20	19
WRITE DATA	Input	22	21
WRITE GATE	Input	24	23
TRACK 00	Output	26	25
WRITE PROTECT	Output	28	27
READ DATA	Output	30	29
SIDE ONE SELECT	Input	32	31
READY	Output	34	33

Table 4-2 Signal Connector Pin Arrangement (J1/P1)



4.1 Signal Interface

The signal interface is classified into control signals and data signals. These interface signal lines are all at TTL levels. The meanings and characteristics of the signal levels are as follows:

- o True = Logical "0" = VL 0 V to +0.4 V
I_{in} 40 mA maximum
- o False = Logical "1" = VH +2.5 V to 5.25 V
I_{in} 0 mA
- o Input impedance = 150 ohms

4.1.1 Cabling method and input line termination

The M4851 uses a daisy chain cabling system. A single ribbon cable or twisted-pair cable may be fitted with multiple connectors to permit connection of up to four drives.

The connected drives are multiplex-controlled by drive select lines, and any one of the drives can be accessed.

The cabling method and input line termination are shown in Fig. 4-1. A maximum of seven input signal lines, plus the drive select lines, may be terminated at the M4851. Proper operation of the drives requires termination at or near the drive connected to the end of the interface cable farthest from the host system.

The M4851 has jumper plugs mounted on the printed-circuit board to terminate these input signal lines.

When a drive is shipped from the factory, its terminators are installed on the printed-circuit board.

Keep the terminators connected in the drive that is at the end of the interface cable, and disconnect the terminators in all the other drives.

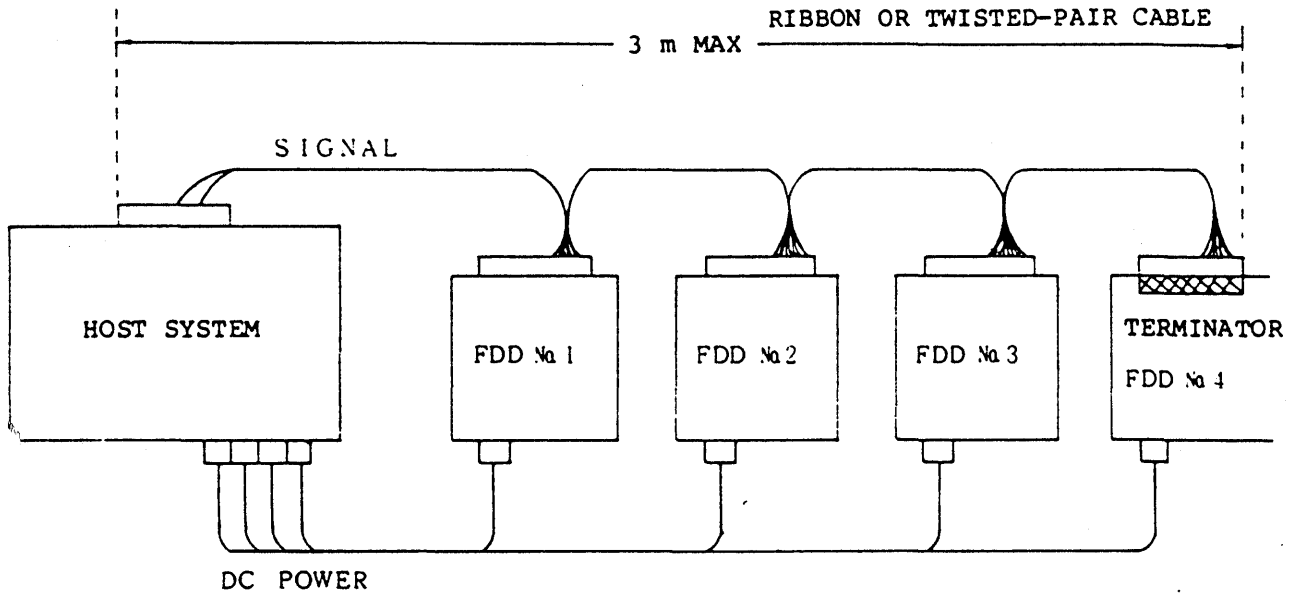

Figure 4-1 Cabling Method

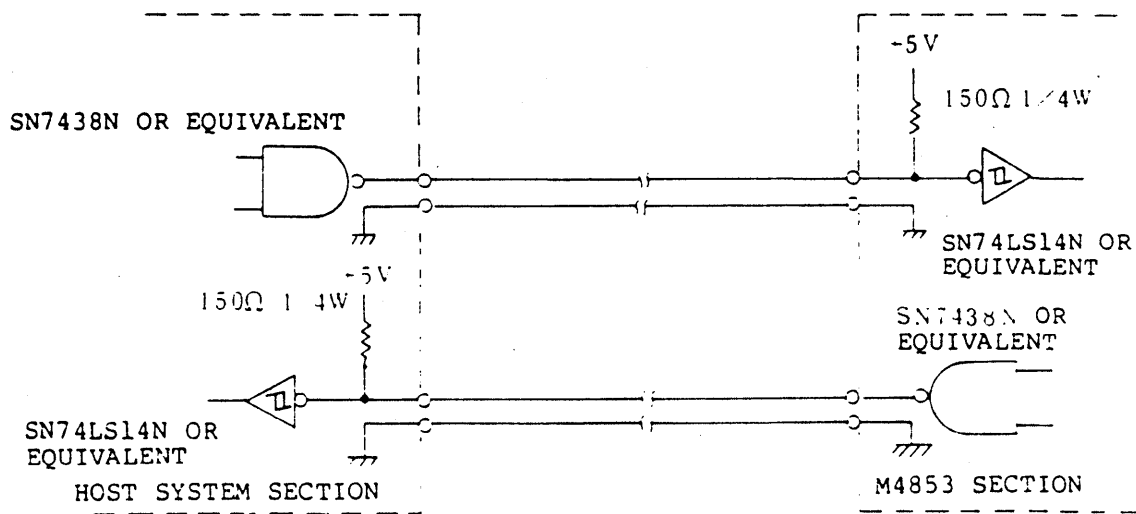

Figure 4-2 Recommended Line Drive and Receiver Circuit



4.1.3 INPUT SIGNAL LINES

The M4851 has 11 input signal lines. Input signals can be classified into two types: One is multiplexed in a multi-drive system; and the other performs a multiplex operation.

The multiplexing signals are:

- o Drive select 0
- o Drive select 1
- o Drive select 2
- o Drive select 3

4.1.3.1 Drive select 0 to drive select 3

When one of these drive select lines are at logical "0" level, the multiplexed I/O lines become active to enable read/write operation. These four separate input signal lines, drive select 0 to drive select 3, are provided for connecting four drives to one system and multiplexing them. Jumper pins DS0, DS1, DS2, and DS3 on the printed-circuit board are used to select the drives to be made active, corresponding to drive select lines.

DS0 is shorted before shipment from the factory, so this setting must be changed when establishing other drive identifications are desired.

4.1.3.2 Side one select

This interface line is used to select which of the two sides of the diskette should be read or written. When this line is at logical "1", the Side 0 head is selected; or when it is at logical "0", the Side 1 head is selected. If the polarity of the side one select signal is reversed, delay read/write operation by more than 100 us before execution.

Upon completion of a write operation, reverse the polarity of the side one select signal after a delay of 1000 us. The heads are tunnel erase type, with a physical gap deviation between the read/write head and the erase heads so with no delay non-erased areas would be generated on the



diskette due to a timing difference between the write data area and the erase area during write operation. This is prevented by delaying the erase current cutoff time of a few hundred microseconds within the M4851. Therefore, the head select must not be reversed during this delay time. Also, the track access action is not permitted for 1000 us.

4.1.3.3 Direction select

This interface line controls the direction (inward or outward) in which the read/write head should be moved when a step signal pulse is applied.

If the signal is at logical "1", the read/write head moves from the center of the diskette outward; if it is at logical "0", the head moves inward.

4.1.3.4 Step

This interface line is a pulsed signal for moving the read/write head in the direction defined by the direction select line. The read/write head moves by one track each time a signal pulse is applied to the step line. The step line is normally logical "1", and the step operation starts with the trailing edge of a negative-going pulse (reversal from logical "0" to logical "1").

The direction select line must be reversed more than 1 us before the trailing edge of the step pulse.

4.1.3.5 Write gate

When this interface line goes to logical "0", the write driver becomes active and the data given to the write data line is written on the selected side of the diskette. When the interface line goes to logical "1", the write driver becomes inactive to enable the read data logic. The verified read data is obtained 1000 us (maximum) after the write driver becomes inactive.



4.1.3.6

Write data

Data to be written on the diskette is sent to this interface line.

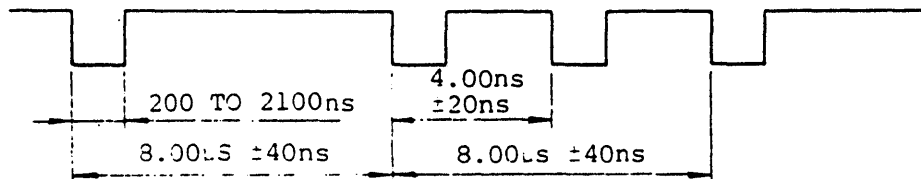

Figure 4-3 Write Data Timing (FM encodings)

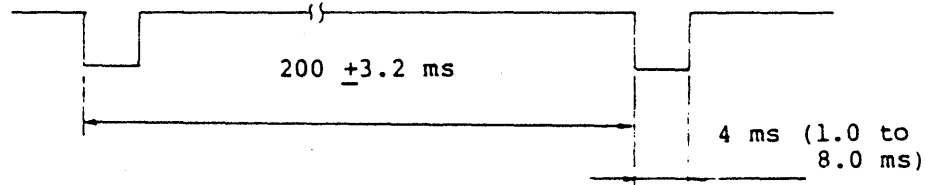
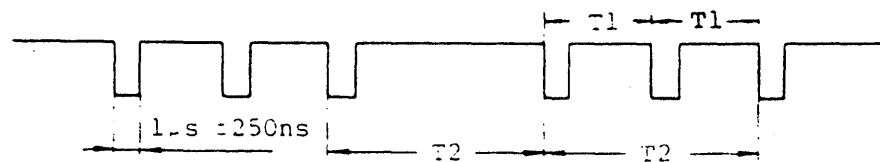

Figure 4-4 Index Timings



$T_1 = 4.00 \mu s \pm 800 \text{ ns}$ (Jitter due to rotation variation excluded)

$T_2 = 8.00 \mu s \pm 1.6 \mu s$ (Jitter due to rotation variation excluded)

Figure 4-5 Read Data Timing (FM Encodings)

This line is normally at logical "1", and reverses the write current at the leading edge of a negative-going data pulse (reversal from logical "1" to logical "0") to write data bits.

This line is enabled when the write gate is at logical "0", Fig. 4-3 shows the write data timing.

4.1.3.7

In use

An LED indicator on the front panel lights when this interface line goes to logical "0". The LED is also lit by the drive select. See Section 7.0 for related options.

4.1.3.8

Motor on

This interface line starts the spindle motor when it goes to logical "0". See Section 7.0 for related options.

The motor-on line goes logical "1" to stop the motor and keep it off while the drive is out of operation, thus reducing system heat generation.

4.1.4

OUTPUT SIGNAL LINES

The M4851 has five standard output signal lines. All of them are multiplexed by the drive select lines. Until the unit is enabled by its drive select input, all of the outputs are in the "off" state.

4.1.4.1

Index

This interface line is normally logical "1" but sends a logical "0" output pulse 4 ms wide each time the diskette makes one revolution (200 ms period).

This signal signifies the start of a track on the rotating diskette. The index signal timing is shown in Fig. 4-4.



4.1.4.2 Track 00

When this interface line is at logical "0", it indicates that a read/write head of the selected drive is positioned on track 00. If the output of the selected drive is at logical "1", it indicates that the read/write head is positioned on a track other than track 00.

4.1.4.3 Ready

This interface line is logical "1" when the door is open or no diskette is in the drive. The line goes logical "0" (ready) if an index pulse is detected twice or more, DC power (+5 V and +12 V) is within limits, and a diskette is inserted into the drive and the door is closed. See Section 7.0 for related options.

4.1.4.4 Read data

This interface line transmits the data that is detected by the read/write head on the diskette.

The read data line is normally logical "1" but it sends a logical "0" (negative-going) output pulse during a read operation. Fig. 4-5 shows allowable limits on timing variations with the usual diskette and bit shifts.

4.1.4.5 Write protect

This interface signal notifies the host system of the insertion of a diskette without a write protect notch into the drive. The signal goes to logical "0" when a write-protected diskette is inserted into the drive. When the signal is at logical "0", writing on the diskette is inhibited even if the write gate line becomes active.

4.2 POWER INTERFACE

The M4851 requires two types of DC power supplies.

One is +12 V DC, which drives the drive motor to rotate the diskette. It is also supplied to the stepping motor and the read/write circuit. The other is +5 V DC, which is used for the logic circuits and the read/write circuit.

4.2.1 DC Power

DC power is supplied via connector J2/P2 on the back of the printed-circuit board. The specifications of the two DC voltages are shown in Table 4-3. The pin arrangement of connector J2/P2 is shown in Table 4-1.

DC voltage	Voltage variation	Current	Maximum ripple voltage (peak-to-peak)
+5 V DC	± 0.25 V	0.7 A maximum	50 mV
	($\pm 5\%$)	0.5 A typical (seeking)	
+12 V DC	± 0.6 V	1.00 A maximum	100 mV
	($\pm 5\%$)	0.5 A typical (seeking)	

Table 4-3 DC Power Specifications



5.0 PHYSICAL INTERFACE

Electronic interfaces between the M4851 and the host system are accomplished with three connectors. Connector J1 is for the signal interfaces, connector J2 for the DC power supplies, and connector J5 for frame grounding. The connectors used for the M4851 and recommended mating connectors are described below.

5.1 Signal Connector

J1 is a card-edge type, 34-pin (for both sides, or 17 pins for a single side) connector with even-numbered pins (2,4, to 34) on the parts side and odd-numbered pins (1,3, to 33) on the soldered side.

A key slot is provided between pins 4 and 6 for the polarity reversal prevention.

The dimensions of J1 are shown in Fig. 5-1.

Recommended P1 connectors that mate with J1 are shown in Tables 5-1 and 5-2.

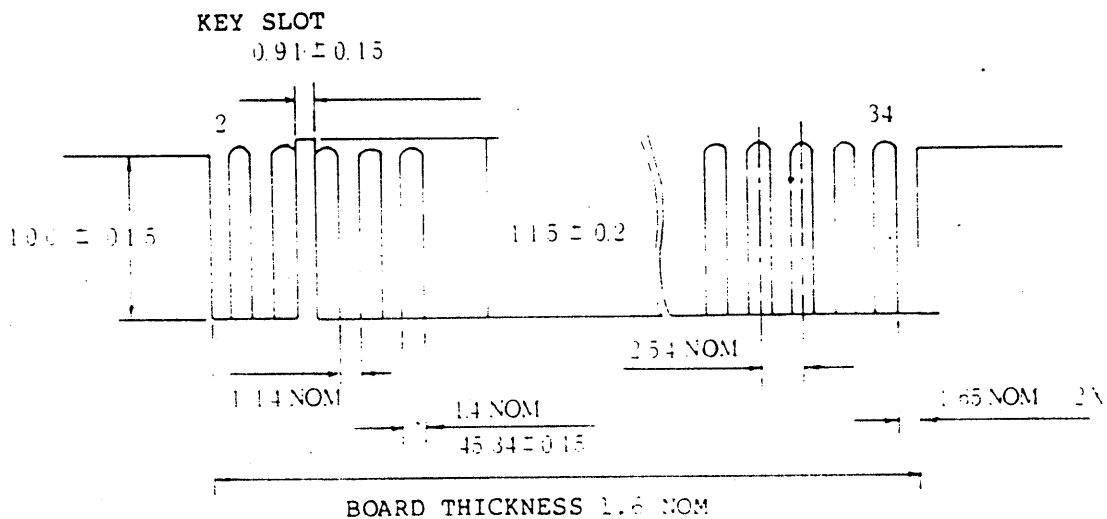

Fig. 5-1 Connector J1 Dimensions (mm) and Pin Numbers

Parts	Crimp type AMP P/N	Solder Type AMP P/N
Housing	583717-5	583717-5
Contact	1-583616-1	583854-3
Polarity key	583274-1	583274-1
Crimping tool	90268-1	-
Extraction tool	91073-1	91073-1
Twisted-pair cable (3 m maximum)	AWG 26	AWG 26

Table 5-1 Connectors for Twisted-Pair Cable (P1)

<u>Parts</u>	<u>3M P/N</u>
Connector	3463-0001
Polarity key	3439-0000
Press	3440
Crimping tools	
Locator press	3443-11
Platen	3442-3
Flat cable (3 m maximum)	3365/34

Table 5-2 Connector for Flat Cable (P1)



5.2 DC Power Connector (J2/P2)

J2 is a four-pin DC power connector made by AMP, located on the back of the printed-circuit board. Pin 4 on connector J2 is located closest to J1/P1; the arrangement of the pins as viewed from the side is shown in Fig. 5-2. Pin numbers are shown on the parts side.

The connectors on the drive side and cable side are shown in Table 5-3.

Parts	P2 (Cable Side)	J2 (Drive Side)
	AMP P/N	AMP P/N
Housing	1-480424-0	172349-1
Contact (4 pins)	60619-1	-
Crimp tool	90124-2	-
Extraction tool	1-305183-2	-
Cable (3 m max.)	AWG 18	-

Table 5-3 DC Power Connectors

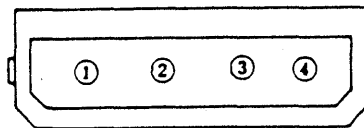

Figure 5-2 Connector J2



5.3 Frame Ground Connector (J5/P5)

FASTON Terminal

AMP P/N 60920-1

Crimp Terminal

AMP P/N 60972-1



5.4 Interface Connector Physical Location

Fig. 5-3 shows the physical locations of the interface connectors used for the M4851.

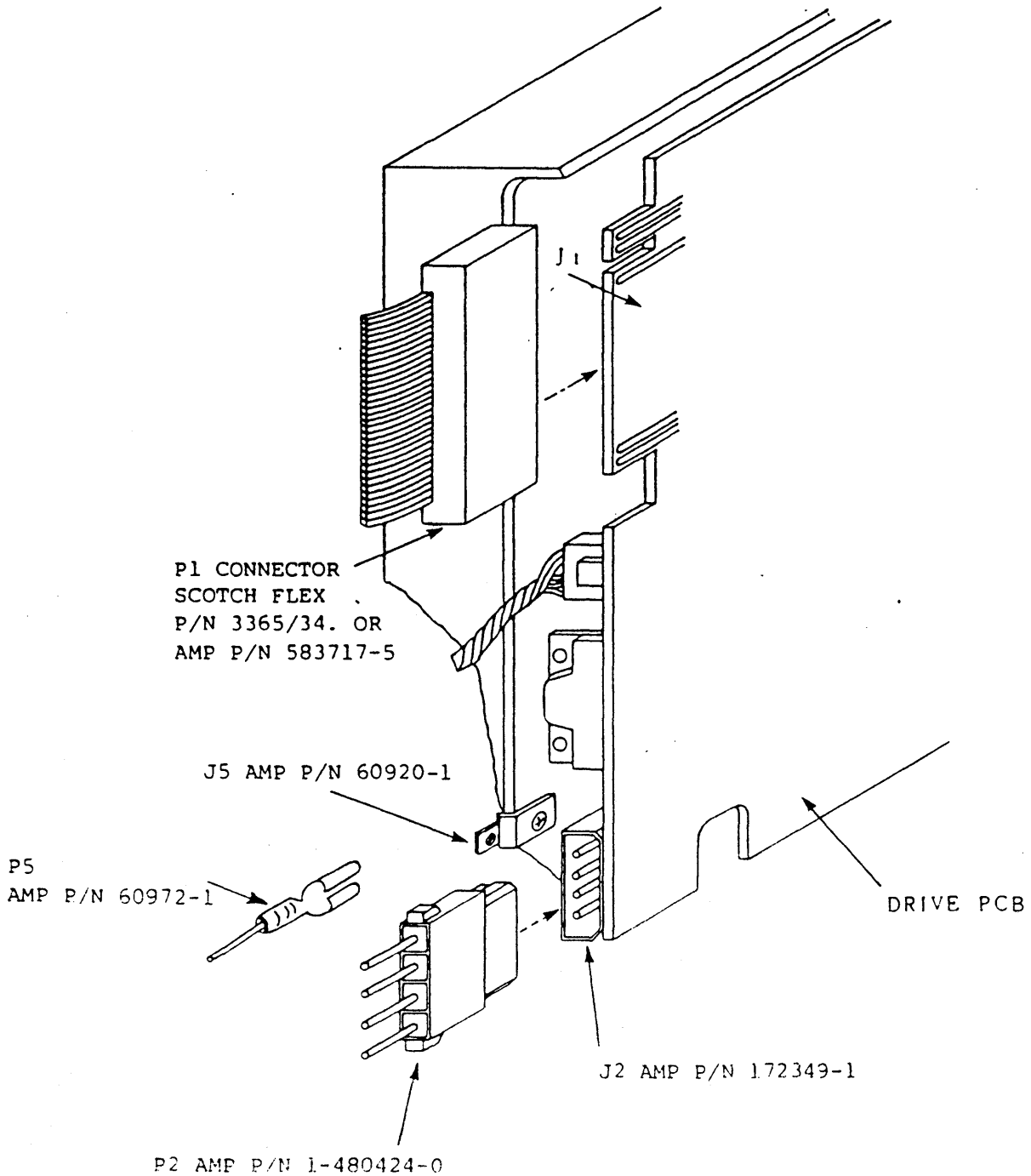

Fig. 5-3 Connector Location Diagram (Rear View)



6.0 PHYSICAL SPECIFICATIONS

6.1 INSTALLATION DIRECTION

Install the M4851 disk drive in the directions shown in Fig. 6-1.

Slant mounting should be within 10 degrees of perpendicular.

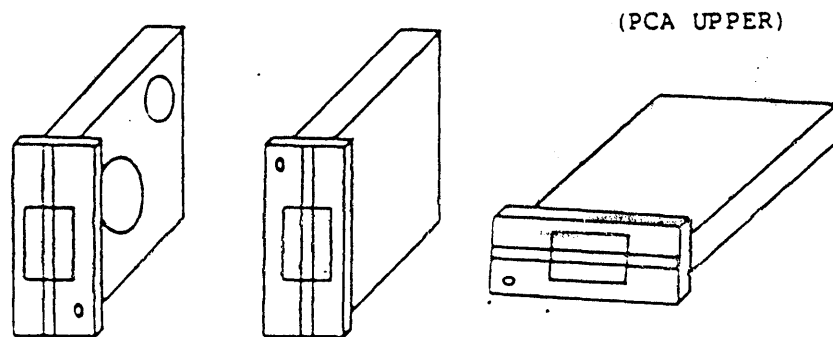
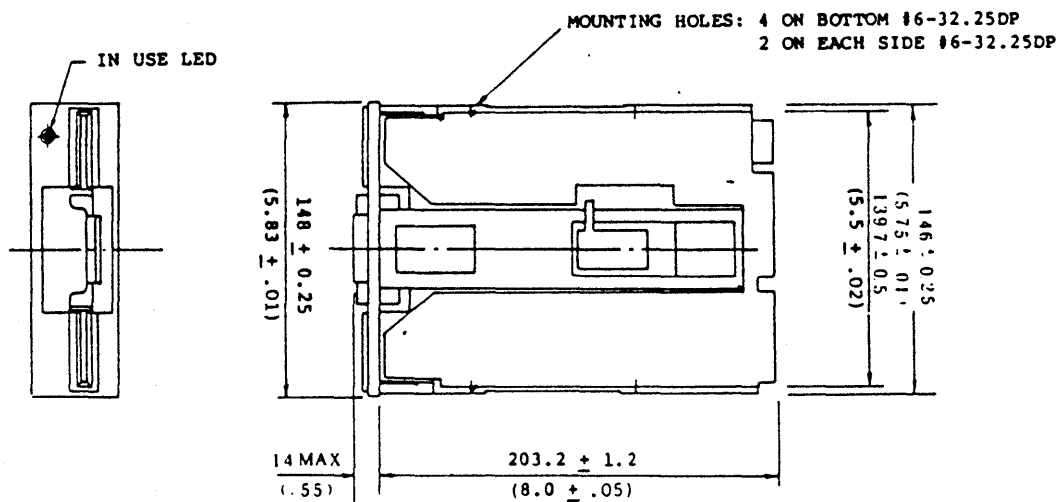

Fig. 6-1 Disk Drive Installation Directions

6.2 DIMENSIONS OF M4851

See Fig. 6-2



Note: All dimensions are in mm
dimensions in () are in inches

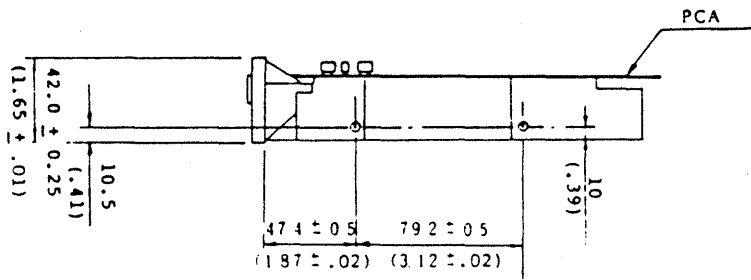

Figure 6-2 Dimensions of M4851



7.0 USER OPTIONS

Non-standard modes of operation are available to the customer by using option plugs, and some PCB cut and/or jumpers. When using a plug, installing the option plug on a pair of square pins is a "short" condition, and removing it is an "open". A trace or a soldered wire jumper between two pads is a "short", and none is a "open".

The specific options are explained below.

7.1 DS0 to DS3

When two or more FDDs are connected to the system, jumper one of the four choices to allow the drive to be enabled when the particular select line is taken to a logical "0" condition.

Only one drive per system may be designated for each drive number. In other words, there can only be one drive "0", etc., in a system.

7.2 MX

If only one FDD is in a system, this option may be used to constantly select the drive. It causes the drive to ignore the status of the "DS" lines.

This jumper must be removed in multi-drive systems.

7.3 HS

This plug is installed to cause the heads to load when the drive is selected by DS0 through DS3. This occurs after the drive is "ready" (see section 7.8). Do not install HC with this option, but HM may also be used at the same time.



7.4 HM

This plug is installed to cause the heads to load when the motor on line (P1-16) is brought to a logical "0" level. This occurs after the drive is "ready" (see section 7.8). Do not install HC with this option, but HS may also be used at the same time.

7.5 HC

This plug is installed to cause a constant head load condition which occurs after the drive is "ready" (see section 7.8) to allow for proper seating of the floppy disk. Do not install HS or HM with this option.

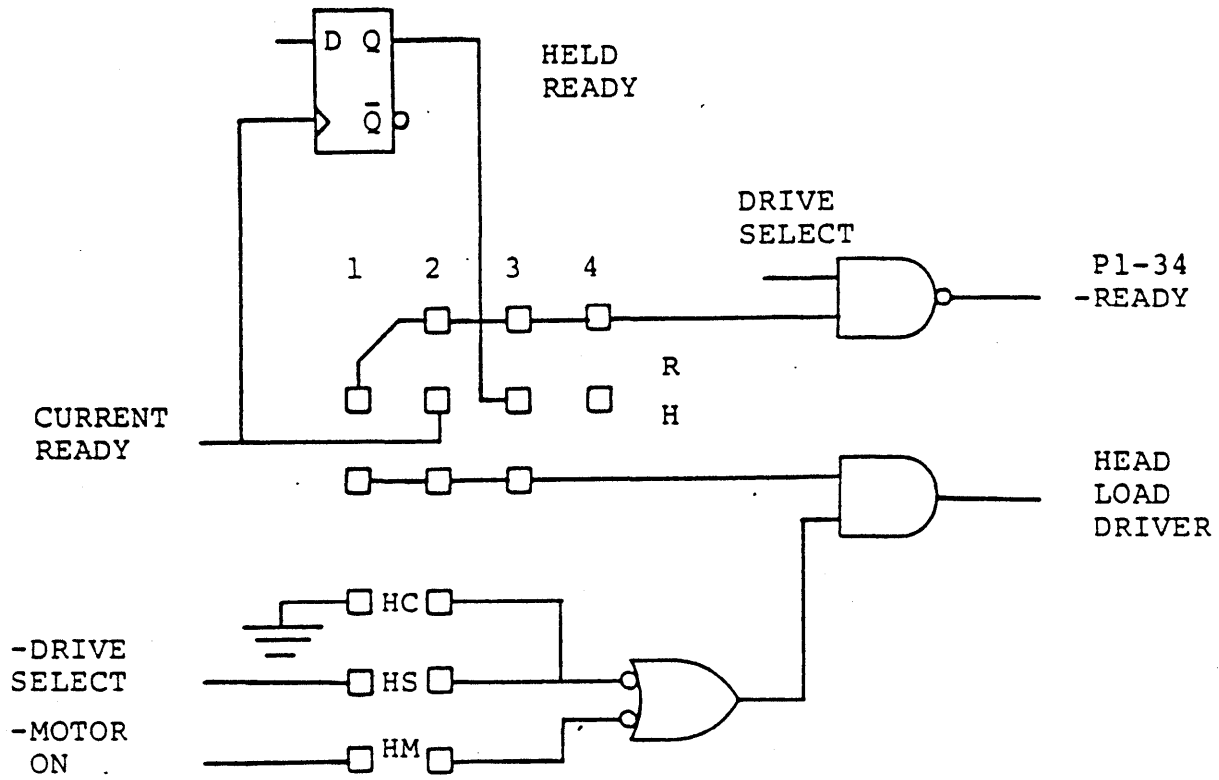

Figure 7-1 H and R Jumper Options



7.6 MM

This plug is installed to cause the spindle motor to turn on and rotate the disk with the input of a logical "0" on the motor on line, P1-16.

7.7 MS

This plug is installed to cause the spindle motor to turn on and rotate the disk when the drive is selected by applying a logical "0" on one of the drive select lines, DS0 through DS3.

7.8 H-1

The "H" jumper is used to select a ready qualifier for the head load control circuit. In this case the ready signals are the internal, un-multiplexed ones that are always operable, even if the drive is not selected.

Installing the "H" jumper in position 1 routes whatever type of "ready" signal is selected to be outputted from the drive to the head load circuit ready qualification input. This is done when both the H and R jumpers should be installed on the same option (H-2, R-2 or H-3, R-3), which is physically impossible. For example, in the case of H-3, R-3, the R jumper should be installed in the R-3 position, and the H jumper should be installed in the H-1 position.

7.9 H-2

Installing the "H" jumper in position 2 routes the "current status" ready signal to the head load circuit ready qualification input. See section 7.11.

7.10 H-3

Installing the "H" jumper in position 3 routes the "held status" ready signal to the head load circuit ready qualification input. See section 7.12.

7.11 R-2

Installing the "R" jumper in position 2 selects a "current status" ready output for the drive. The output goes to a logical "0" when the floppy disk is rotating at the proper speed and the drive is selected.



7.12 R-3 (Disk Change)

Installing the "R" jumper in position 3 enables a "held status" ready output from the drive. The output will be a logical "0" when a disk is inserted and correctly clamped in the drive. (Index pulses were detected correctly.) This ready condition is held even if the drive is not selected and the motor is not on. It is an indicator that a disk is inserted in the drive and the door is closed. It is reset (to a not ready state), if the door is opened, which allows the disk to be ejected.

7.13 R-4

This option must not be used.

7.14 MC

Cutting this PCB trace causes the spindle motor to run whenever a floppy disk is inserted in the drive.

7.15 RD-RS

This option is not used at this time.

7.16 DI

Cutting this PCB trace disables the in-use input to the drive (Pl-4). This means that the only time the front panel LED will be lit will be when the drive is selected. The MX option cannot be used in conjunction with this modification; the in use LED will never be illuminated if it is.

7.17 Write Protect Inversion

The option pads between IC's M1 and L1 are used to invert the logic of the write protect slot on the floppy disk. The trace from the center pad to the in-board pad must be cut, and the center pad must be jumped to the out-board pad to enable this option.

7.18 Input Terminations

All input lines to the drive are terminated (see section 3.1.1). The jumper plug located between IC's C5 and D5 should be removed on drives in multi-drive systems, with the exception of the drive the farthest electrical distance from the controller.



7.19.0 Options Timing Examples

7.19.1 HS, R3, H1

- o HS = Shorted (Head Load with Drive Select)
- o HM = Open
- o R3 = Shorted (Held Ready Output)
- o H1 = Shorted (Head Load with Held Ready)
- o All other H and R positions are open

Ready delay from Drive select = 500 nSec max

Valid read data delay from Drive Select = 250 mSec max

The head is loaded at the same time as the motor is started. The Ready signal signifies a disk installed state, not a data ready condition.

7.19.2 HS, R2, H3

- o HS = Shorted (Head Load with Drive Select)
- o HM = Open
- o R2 = Shorted (Current Ready Output)
- o H3 = Shorted (Head Load with Held Ready)
- o All other H and R positions are open

Ready delay from Drive Select = 600 mSec max

Valid read data delay from Drive Select = 250 mSec max

The head is loaded at the same time as the motor is started. The Ready signal can be used as a valid data in a motor start situation.

7.19.3 HS, R2, H1

- o HS = Shorted (Head Load with Drive Select)
- o HM = Open
- o R2 = Shorted (Current Ready Output)
- o H1 = Shorted (Head Load with Current Ready)
- o All other H and R jumpers are open

Ready Delay from Drive Select = 600 mSec max

Valid Read Data Delay from Drive Select = 650 mSec max



7.19.4 HM, R3, H1

- o MM = Shorted (Motor-On Input Active)
- o HS = Open
- o HM = Shorted (Head Load with Motor On)
- o R3 = Shorted (Held Ready Output)
- o H1 = Shorted (Head Load with Held Ready)
- o All other Hand R jumpers are open

Ready Delay from Drive Select = 500 nSec max
Delay from Motor On until drive may be selected =
250 mSec min

This option setting combination would be used for disk to disk transfers with a minimum of delays. Because the head was loaded during motor start up, there is no head settling time required after a drive select. (If the spindle motors are constantly on.) This option is also good for a controller that "polls" the disk drive for its status, because it will not load the head every time the drive is selected to sample its status.



7.20 Options summary

NAME	LOCATION	DESCRIPTION	TYPE CONNECTION	FACTORY SHIPMENT	
				Open	Short
DS0	6B	Drive Address 0	Plug		X
DS1	6B	" " 1	"	X	
DS2	6B	" " 2	"	X	
DS3	6B	" " 3	"	X	
MX	6B	Continuous Drive Select	"	X	
HS	6B	Head Load W/Drive Select	"		X
HM	6B	" " W/Motor On	"	X	
HC	6B	" " Constantly	"	X	
MM	5E	Motor On-Motor On Input	"		X
MS	5E	Motor On-Drive Select	"	X	
H1	2L	Head Load-Drive Ready	"		X
H2	2L	Head Load-Current Status	"	X	
H3	2L	Head Load-Held Status	"	X	
R2	2L	Ready Output-Current Status	"		X
R3	2L	Ready Output-Held Status	"	X	
R4	2L	Not Used-Leave Open	"	X	
MC	2E	Motor Constantly On	Trace		X
RD	2K	Not Used-Leave Open	"	X	
RS	2K	Not Used-Leave Shorted	"		X
DI	6B	Disable In Use Input	"		X
-	2M	Write Protect Inversion	"	Note 1	Note 1
	6B	Input Terminations	Plug		7

Notes: 1) See Section 7.17 for description of this unmarked option.



8.0 RECORDING FORMAT

Data to be recorded on the floppy disk is grouped in various blocks.

There are bits, bytes, sectors, tracks, and sides. The bits are encoded onto the disk by three possible means: FM, MFM, or MMFM techniques. These bits are collected together in a certain number of bytes per sector to define the actual recording format used. All of this is defined by the host system; the disk drive just records and detects flux reversals on the disk.

8.1 BIT ENCODING

As stated before, there are three main methods of encoding bits on a floppy disk. All have some advantages and disadvantages, but the generally accepted standard is MFM (also called Double Density).



8.1.1 FM Encoding

FM (Frequency Modulation) encoding is shown in Figure 8-1. It is the simplest form of encoding, and may be decoded by used of inexpensive one-shot multivibrators. It can do this because each data pulse is between two clock pulses, thereby rigidly defining the "read window" very precisely.

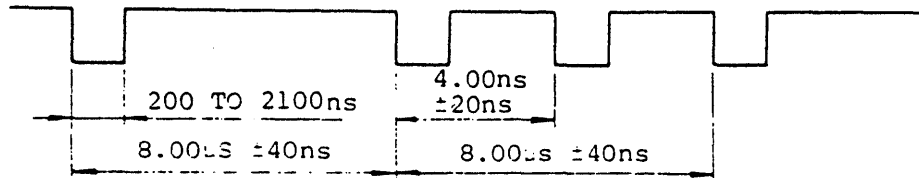
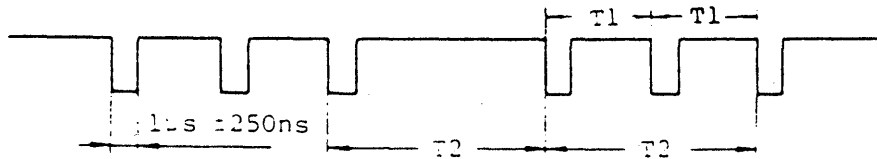

Figure 8-1 FM Write Timing



$T_1 = 4.00 \mu s \pm 800 ns$ (Jitter due to rotation variation excluded)

$T_2 = 8.00 \mu s \pm 1.6 \mu s$ (Jitter due to rotation variation excluded)

Figure 8-2 FM Read Timing



8.1.2 MFM Encoding

MFM (Modified Frequency Modulation) encoding records twice the number of bits per inch (linear recording density) as FM encoding, but has the same number of flux changes per inch. It does this by removing the clock pulses, and shrinking the bit cell space by 50%. See Figure 8-3 and 8-4 for specific details. Clock bits are always written at the leading edge of the cell only if no data bits are written in either the present or preceding bit cells.

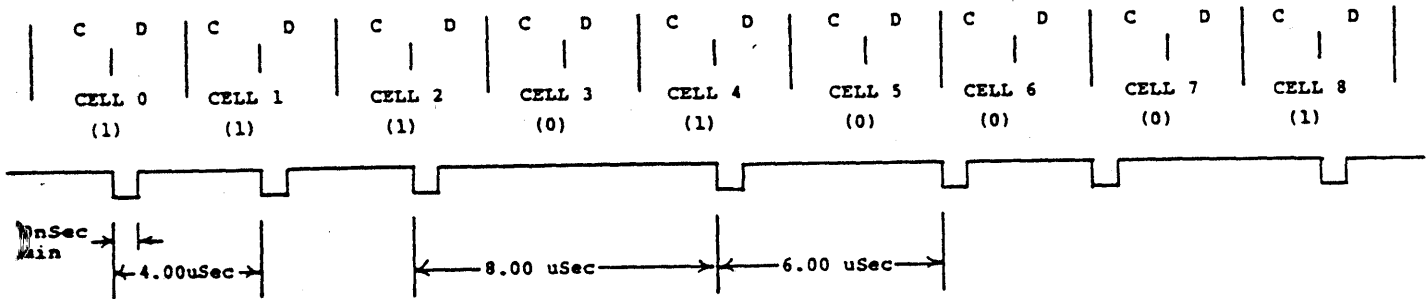

Figure 8-3 MFM Write Timing

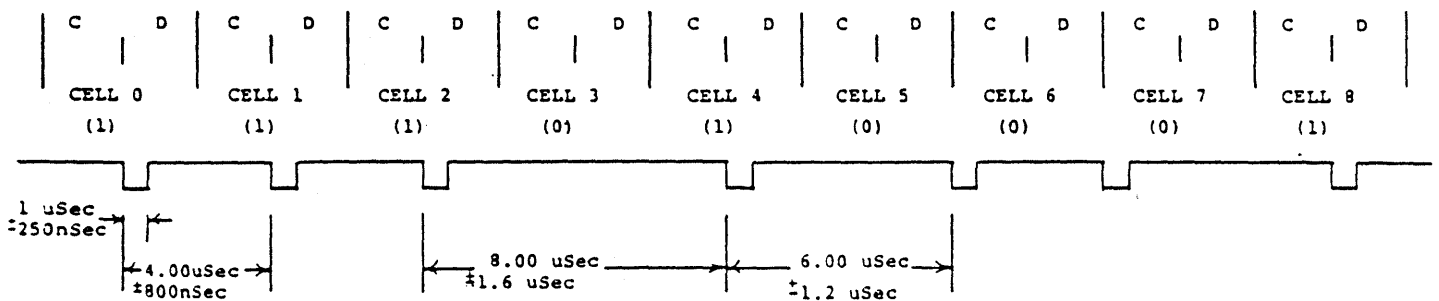

Figure 8-4 MFM Read Timing



8.1.3 MMFM Encoding

MMFM (Modified-Modified Frequency Modulation) is also a "double density" encoding method, but it further reduces the number of clock bits used to fill the empty spaces between data pulses.

It is not a standard encoding technique, and should probably be avoided for that reason. See Figure 8-5 and 8-6 for a description of MMFM. The data bits are written in the middle of the data cells, but a clock pulse is encoded only if no clock or data pulses were written in the previous bit cell, and no data bit is to be written in the present one.

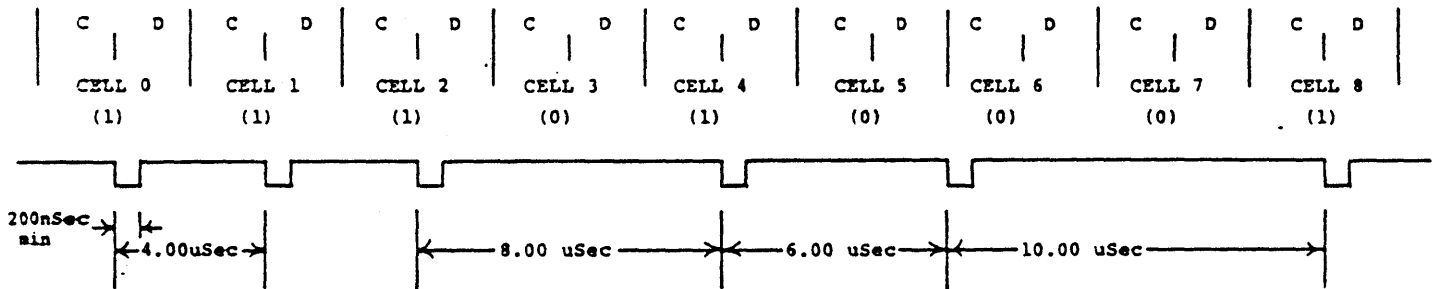

Figure 8-5 MMFM Write Timing

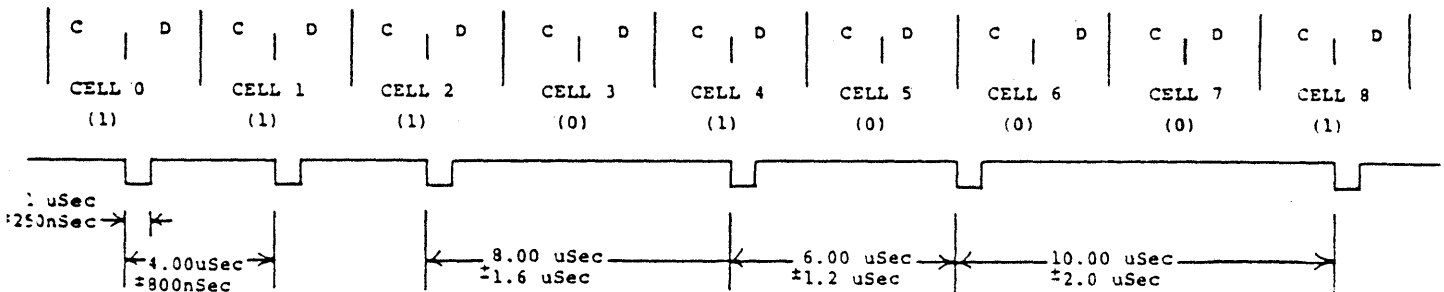

Figure 8-6 MMFM Read Timing



8.2 M4851 RECOMMENDED FORMATTINGS

M4851 5.25 inch (130 mm) Flexible Disk Drives use industry standard Tunnel Erase type Read/Write Heads, and high accuracy direct-drive brushless motor for spindle rotation, guaranteed $\pm 1.6\%$ index interval and $\pm 2\%$ instantaneous speed.

The recommended formattings for data interchange between drives are shown in the following figures, including formatting and data re-write modes.

The drives allow for the following conditions on all 40 tracks.

- (1) The leading edge of a data block should be preceded by the erased area when re-written.
- (2) The trailing edge of a data block should be covered by the erased area when re-written.
- (3) The erased area should not overlap with Sector Identifiers.
- (4) Read/Write gap should be before the next ID mark when the erase current is falling off when re-write with the fast rotation spindle on a slow formatted sector.

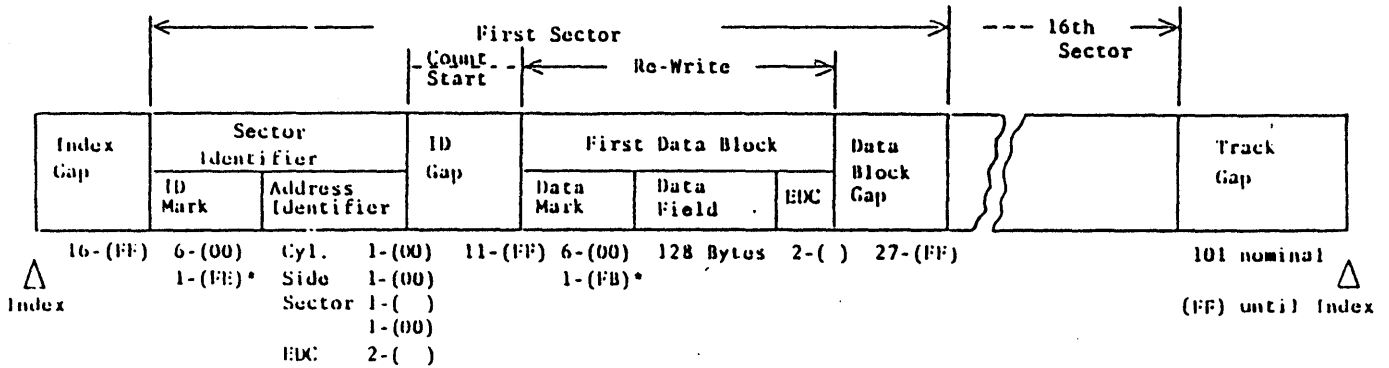

Figure 8-7 ISO-7487/2 Style, Track 00, Side 0 (FM)

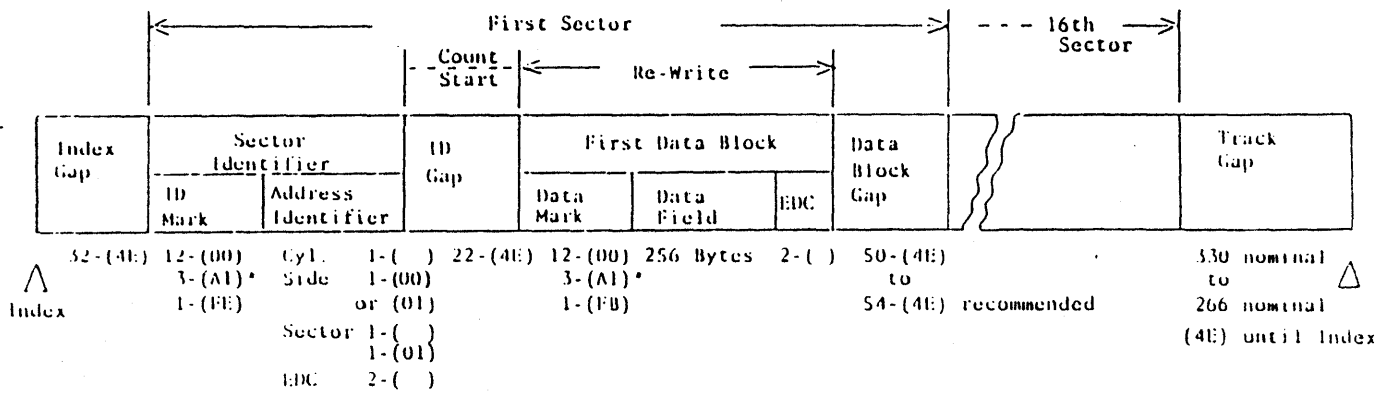

Figure 8-8 ISO-7487/2 Style, All Other Tracks (MFM)

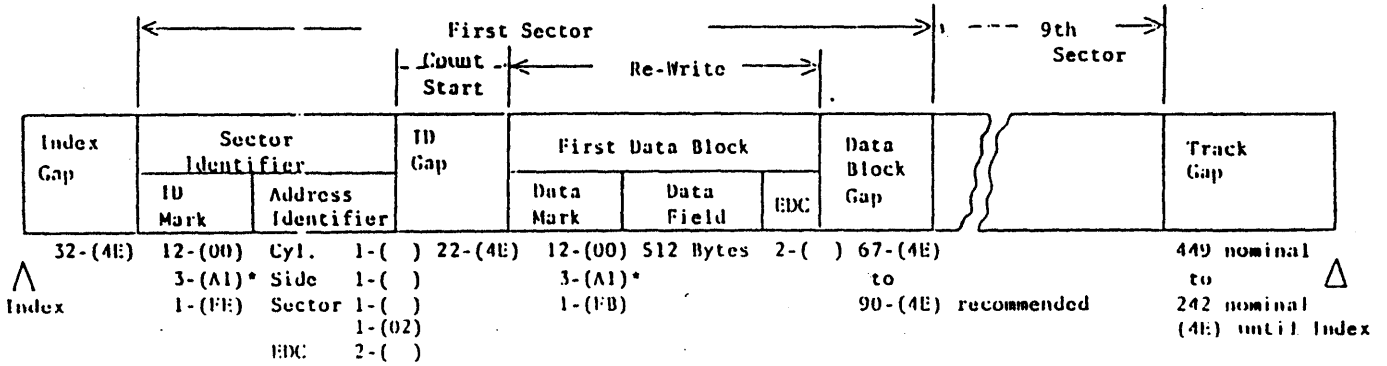

Figure 8-9 512 Bytes/Sector, Standard

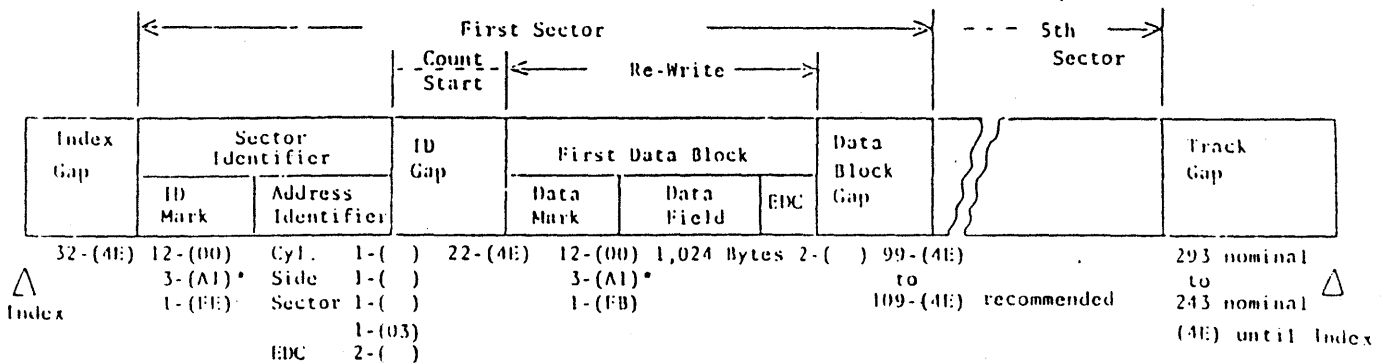

Figure 8-10 1,024 Bytes/Sector, Standard

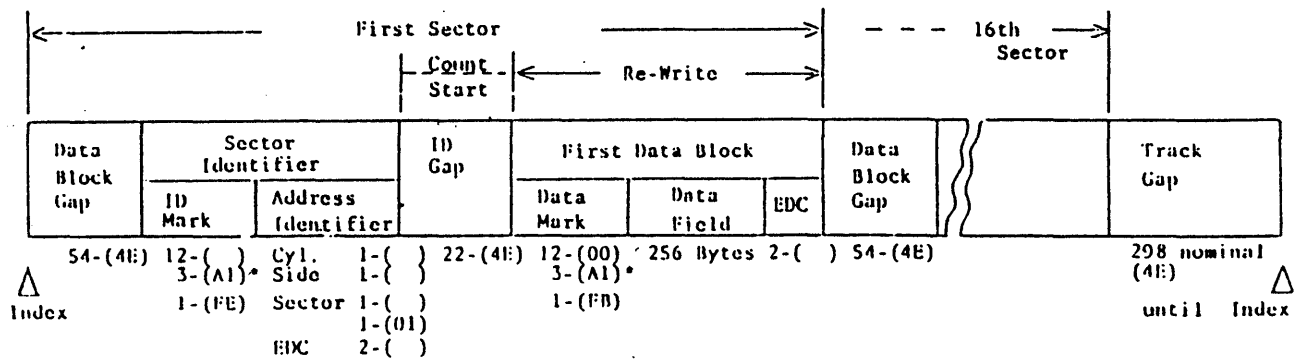

Figure 8-11 256 Bytes/Sector, Simplified

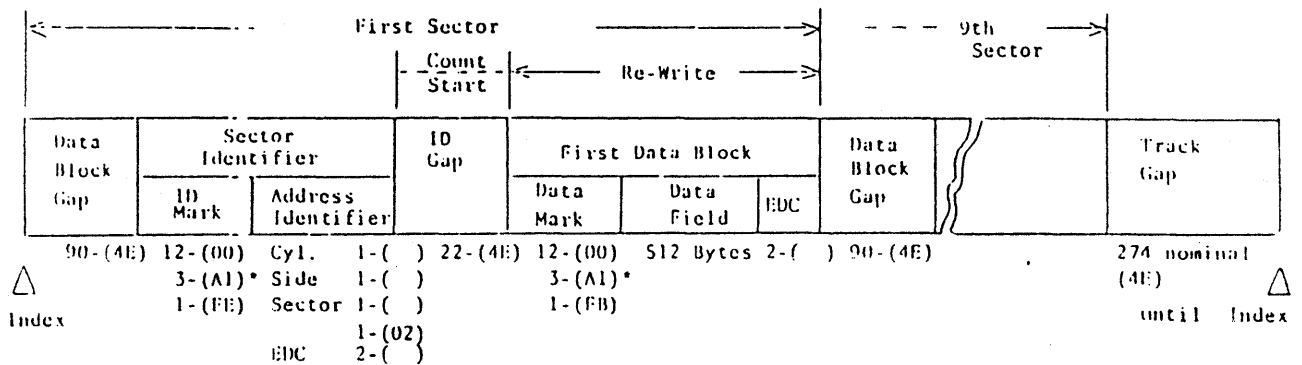

Figure 8-12 512 Bytes/Sector, Simplified

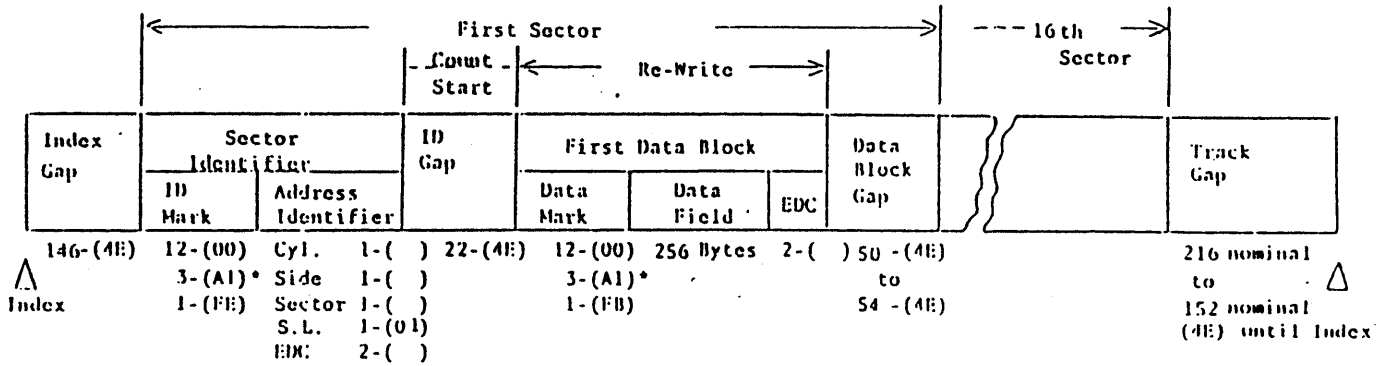

Figure 8-13 256 Bytes/Sector, NEC 765A

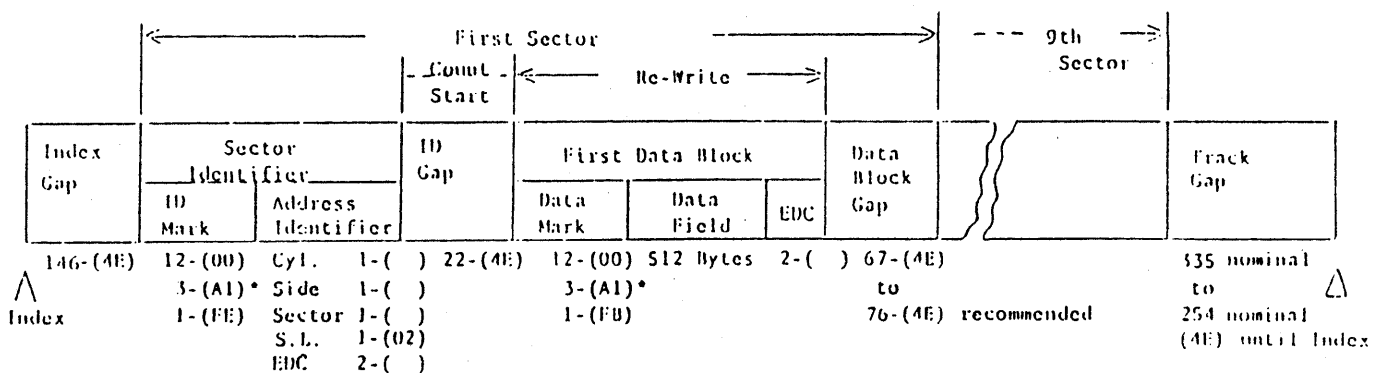

Figure 8-14 512 Bytes/Sector, NEC 765A

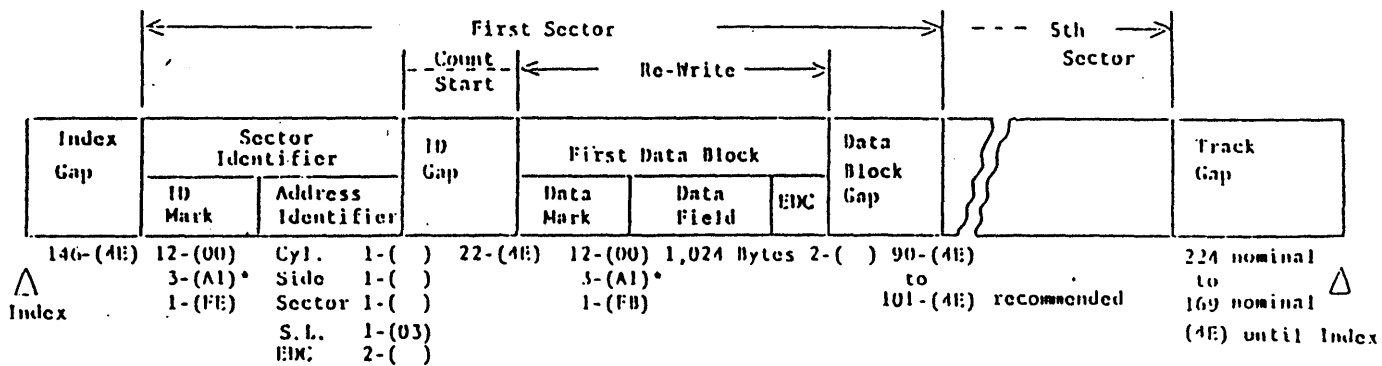

Figure 8-15 1,024 Bytes/Sector, NEC 765 A



8.3 ERROR DETECTION AND CORRECTION

8.3.1 Write Errors

If an error occurs during a write operation, it can be detected by performing a read operation on the diskette immediately following the write operation. This is generally called a write check, which is an effective means of preventing write errors. It is recommended, therefore, that a write check be made without fail.

If a write error occurs, repeat the write operation and conduct a write check. If data cannot be correctly written even after the write operation is repeated about ten times, perform a read operation on another track to determine whether the data can be read correctly. If so, a specific track of the diskette is defective. If data cannot be correctly read on the other track, the drive is assumed to have some trouble.

If the diskette is defective, replace it.

8.3.2 Most data errors that occur are soft errors. If a read error occurs, repeat the read operation to recover the data.

The following are possible main causes of soft errors:

- o Dust is caught between the read/write head and diskette causing temporary fault in head contact. Such dust is generally removed by the self-cleaning wiper of the jacket, and the data is recovered by the next re-read operation. If read/write is continued for a long time in a very dusty environment, however, hard errors can result from a damaged diskette surface.
- o Random electrical noise ranging in time from a few microseconds to a few milliseconds can also cause read errors. Spike noise generated by a switching regulator, particularly one that has short switching intervals, deteriorates the signal-to-noise ratio, and increases the number of re-read operations for data recovery. It is necessary, therefore, to make an adequate check on the noise levels of the DC power supplies to the drive and frame grounding.



- o Written data on diskettes may have so small a defect as cannot be detected by a data check during write operation.
- o Fingerprints or other foreign matter on a written diskette can also cause a temporary error. If foreign matter is left on a written diskette for a long time, it can adhere to the diskette, possibly causing a hard error.

It is recommended that the following read operations be performed to correct these soft errors:

- o Step 1: Repeat the read operation about ten times, or until the data is recovered.
- o Step 2: If the data cannot be recovered by Step 1, move the head to another track, the opposite direction of the previous track position before the designated track, and then return the head to the original position.
- o Step 3: Repeat an operation similar to Step 1.
- o Step 4: If the data cannot be recovered, assume the error is a hard error.



9.0 RESHIPMENT PRECAUTIONS

When reshipping the drive proper steps must be taken to prevent any damage to the drive.

9.1 Shipping Damage

Any damage to the drive that occurred during shipping is the responsibility of the carrier. Contact the carrier for any damage claims.

9.2 Reshipping

If it is necessary to return a drive for any reason proper steps must be taken to prevent damage to the drive.

- o Use all the packing materials that were received with the drive, if possible.
- o Be sure to utilize the anti-static bag that came with the drive.
- o The head protection sheet should be inserted into the drive (the door should not be closed).