

▶ 4 45

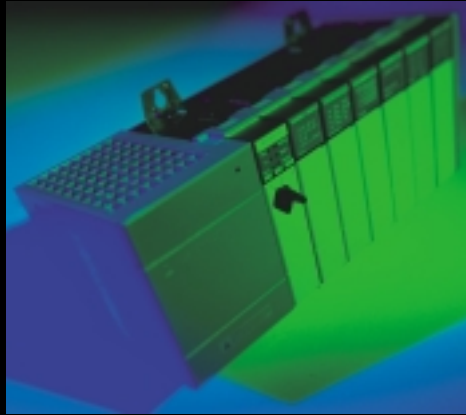

7-SLOT RACK W/ 5/05 ETHERNET® PROCESSOR



▶ 3 44 43

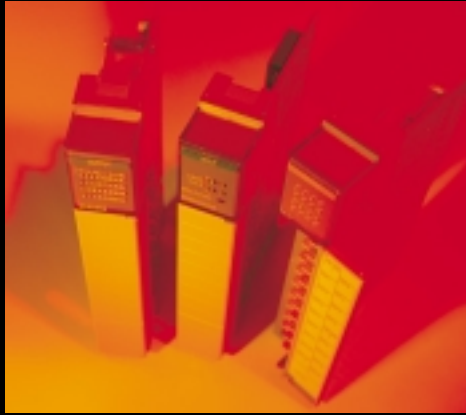

1746 I/O MODULES



▶ 2 42

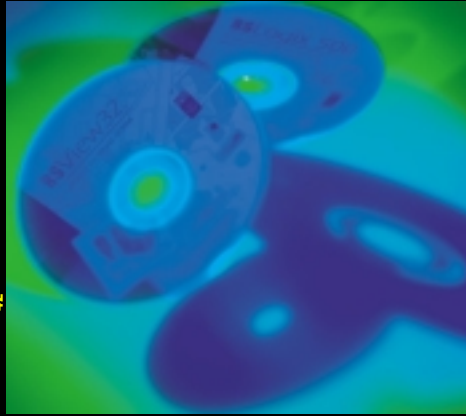

PROGRAMMING AND OI SOFTWARE



▶ 1 41



10-SLOT RACK W/ COMMUNICATION CARDS



System Overview

SLC 500™ Programmable Controllers & I/O Modules

(Bulletins 1746 and 1747)



Bringing Together Leading Brands in Industrial Automation



Take Control

Experience Complete Satisfaction With Allen-Bradley

Since 1903, Rockwell Automation's Allen-Bradley has earned a worldwide reputation as the most trusted brand name in industrial automation. It's a reputation built on a very simple strategy: providing customers with products of uncompromising quality and reliability. The SLC 500™ family is a good case in point. These small logic controllers demonstrate our commitment to the highest standards of product dependability, technological innovation, and performance.

And because your absolute satisfaction is important to us, we back you and our products with the highest levels of customer service and support in the industry. Your local Rockwell Automation representative is your source for expert sales and order support, as well as:

- Product technical training
- Warranty support
- Service agreements

SLC 500 Processors:

The Compact Controllers for Big Applications

Don't be fooled by the SLC 500 size. From food processing to steel fabrication, you won't find a more versatile or powerful solution for stand-alone or distributed industrial control assignments.

Capacity to Do More. Flexibility to Cost Less.

The SLC 500 is engineered with your changing automation needs in mind. With up to 64K of configurable data/program memory available, the SLC 500 line provides the power, flexibility, and expanded I/O selection to take on applications that once required larger, more expensive control solutions. The SLC 500 modular I/O system offers over 60 types of modules — you customize your control applications with a host of modular solutions, including discrete, analog, and specialty I/O modules. If less than 64K of memory gets the job done, you'll reduce project costs by building your system with one of many other memory sizes available.

Reliability for Stand-Alone Control or Distributed Architecture.

The SLC 500 can address high-speed discrete and process control applications from a single platform. This makes it ideal for fast-paced operations like bottling lines and packaging machines. Plus,

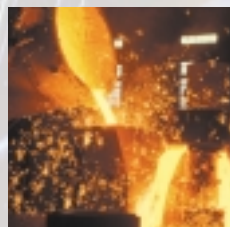



from the plant floor to management information systems. Through Ethernet networks, the SLC 500 can communicate plant-floor data in data acquisition, supervisory control, program management, statistical quality control, production scheduling and material tracking applications.

Peer-to-Peer Communications Versatility

A choice of six networking options delivers superior connectivity. Simply select the built-in communications choice that best fits your application. SLC 500 processors can support 10 Mbps Ethernet® communications with a 10 Base-T Ethernet channel, as well as high-speed peer-to-peer communications with built-in DataHighway Plus™ (DH+). Don't need Ethernet or DH+? Then choose an SLC 500 with built-in DH-485 communications.

comprehensive diagnostics simplify troubleshooting throughout your process.

Top Floor to Shop Floor Communications

With available built-in Ethernet, SLC 500 processors provide that vital enabling communications link

Device-Level Control

Connectivity to the popular 1747-SDN DeviceNet™ Scanner module gives you a single-cable interface to "smart" devices, including sensors, push buttons, motor starters, simple operator interfaces, and drives. This means:

- Low node cost and ease of integration
- Reduced installation costs and wiring
- Additional diagnostics from intelligent devices
- Rapid troubleshooting

Remote I/O Compatibility

Taking advantage of remote I/O (RIO) options is as simple as adding the 1747-SN RIO scanner module to your SLC system. The scanner module and the 1747-ASB RIO adapter module both support discrete and block transfer options. So drives, operator interface, third party devices, and many other RIO-compatible products are easily accommodated.

Available remote I/O passthrough simplifies upload or download applications to MMI devices on the Remote I/O network, including PanelView™ Operator terminals and Dataliner™ Message Displays.

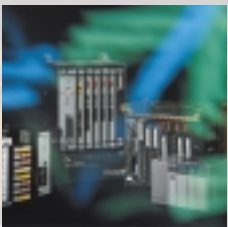

Table of Contents

SLC 500 Family	5
SLC 500 Modular Processors	7
Discrete I/O Modules	13
Analog I/O Modules	18
Temperature Modules.....	21
Counting, Positioning and Motion Modules	26
Application Specific Modules	30
Communication Choices	33
Power Supplies	41
Chassis	43
Programming Options	44
SLC Programming Instruction Set.....	48
7 Steps to Successfully Configuring an SLC 500 System	49
Dimensions	56

SLC 500 Family

The Allen-Bradley SLC 500 is Rockwell Automation's small chassis-based, modular family of programmable controllers (PLC's) and chassis-based I/O. It consists of processors, I/O and peripheral devices. This processor family delivers power and flexibility with a wide range of communication configurations, features, and memory options

The additions of built-in networks, extensions of the 1746 I/O family, availability of third-party specialty I/O modules from Encompass partners, and state-of-the-art Windows programming package have helped to make the Allen-Bradley SLC 500 the premier small controller on the market today.



Features

- Fast, powerful processors with memory sizes up to 64K
- Hundreds of local as well as remote I/O styles and options with 1746, 1771, Block and Flex I/O modules
- On-board Ethernet communications, as well as options for DeviceNet, ControlNet and other networks
- Modularity and flexibility mean you develop the powerful system your application requires by buying exactly what you need
- High-speed discrete capability with specialized I/O
- Process control power: a wide range of analog I/O plus advanced math and PID instructions
- Designed and manufactured for industrial environments, capable of withstanding a wide range of temperature and humidity conditions, as well as handling extremes in vibration and shock
- World standards compliant: UL listed; CSA approved; Class I, Division 2 hazardous environment; Certified for Marine applications; CE compliant for applicable directives

SLC 500 Common Specifications

The following specifications apply to all SLC 500 modular components unless noted.

6

Description	Specification
Temperature	Operating: 0°C to +60°C (+32°F to +140°F)
	Storage: -40°C to +85°C (-40°F to +185°F)
Humidity	5 to 95% without condensation
Vibration	Operating: 1.0G at 5 to 2000 Hz
	Non-operating: 2.5Gs at 5 to 2000 Hz
Shock	Operating: (all modules except relay contact) 30.0Gs (3 pulses, 11 ms)
	Operating: (relay contact modules 1746-0Vx and 1746-IOx combo) 10.0Gs (3 pulses, 11 ms)
	Non-operating: 50.0Gs (3 pulses, 11 ms)
Free Fall (drop test)	Portable, 2.268 kg (5 lbs) or less at 0.762 m (30 in.) (six drops)
	Portable, 2.268 kg (5 lbs) or more at 0.1016 m (4 in.) (three flat drops)
Noise Immunity	NEMA Standard ICS 2-230
Electromagnetic Compatibility	Showering Arc: 1.5 KV (Industry Standard - NEMA ICS 2-230/NEMA ICS 3-304)
	Surge Withstand Capability: 3 KV (Industry Standard - IEEE Std. 472-1974/ANSI C37.90/90A-1974)
	Fast Transient Burst (impulse): 2 KV for 1746 power supplies, 1 KV for 1746 I/O and communication lines over 10m (32.84 ft.), 5 ns rise time
	Electrostatic Discharge (ESD): 15 KV, 100 pF/1.5KW model
	Radiated Electromagnetic Susceptibility: 5W walkie-talkie at 464.5 MHz and 153.05 MHz
Safety	Dielectric Withstand: 1500V ac (Industry Standard - UL 508, CSA C22.2 No. 142)
	Isolation between Communication Circuits: 500V dc
	Isolation between Backplane and I/O: 1500V ac
	Flammability and Electrical Ignition: UL94V-0
Certification (when product or packaging is marked)	<ul style="list-style-type: none"> • CSA certified • UL listed • CUL listed • Class I, Groups A, B, C or D, Division 2 • CE compliant for all applicable directives

SLC 500 Modular Processors

The SLC 500 processors offer a wide range of choices in memory, I/O capacity, instruction set, and communication ports to allow you to tailor your control system to exactly meet your application requirements. These products have a strong reliability history covering hundreds of thousands of installations in a broad range of applications



7

Features

- Simple and affordable processors with extensive capabilities to address a broad range of applications including material handling, HVAC control, high-speed assembly operations, small process control, and SCADA
- Advanced instruction set based on the PLC-5 mid-size processors, and compatible with the MicroLogix family of packaged controllers
- Communications enhancements enable the 5/03, 5/04 and 5/05 to provide master control of SCADA networks
- Powerful features including indirect addressing, high-level math capability and a compute instruction
- Wide range of memory size's from 1K up to 64K

SLC 5/01 Processor (Catalog No. 1747-L511 or -L514)

The SLC 5/01 processor offers a large comprehensive instruction in a modular hardware configuration. The SLC 5/01 processor provides:

- Two choices of program memory size — 1K or 4K instructions
- Control of up to 3940 input and output points
- Powerful ladder logic programming instruction set
- Subroutines
- DH-485 communication channel (peer-to-peer communication response only)
- Capacitor backup for the 1747-L511 (battery backup optional); battery backup standard for the 1747-L514



SLC 5/02 Processors (Catalog No. 1747-L524)

The SLC 5/02 processor offers additional instructions, increased diagnostics, faster throughput, and additional peer-to-peer communication options; building on what the SLC 5/01 processors offer.

The SLC 5/02 processor provides:

- Program memory size of 4K instructions
- Control of up to 4096 input and output points
- PID - used to provide closed-loop process control
- Indexed addressing
- Interrupt capability (10 millisecond STI)
- User fault routines
- Ability to handle 32-bit signed math functions
- DH-485 communication channel (initiation and response of peer-to-peer communication)
- Battery-backed RAM
- Increased processor speed over the SLC 5/01



SLC 5/03 Processors (Catalog No. 1747-L531 or -L532)

The SLC 5/03 processor significantly increases performance by supplying system throughput times of 1 ms for a typical 1K user program. Now applications such as high-speed packaging, sorting, and material handling become more affordable. With the addition of online editing, the SLC 5/03 processor presents a positive solution for your continuous process application. A built-in RS-232 channel gives you the flexibility to connect to external intelligent devices without the need for additional modules. The SLC 5/03 processor provides:

- Total memory size of 8K or 16K
- Control of up to 4096 input and output points
- Online programming (includes runtime editing)
- Built-in DH-485 channel
- Built-in RS-232 channel supporting DF1 Full-duplex, DF1 Half-Duplex Master/Slave for SCADA, DH-485 using a 1761-NET-AIC with a 1747-CP3 cable, and ASCII protocols
- Remote I/O passthrough from channel 0 (DF1) or channel 1 (DH485) using a 1747-SN or 1747-BSN remote I/O scanner module
- DeviceNet passthrough using 1747-SDN DeviceNet scanner module
- Built-in real-time clock/calendar
- 2 ms Selectable Timed Interrupt (STI)
- 0.50 ms Discrete Input Interrupt (DII)
- Advanced math features - trigonometric, PID, exponential, floating point, and the compute instruction
- Indirect addressing
- Flash PROM provides firmware upgrades without physically changing EPROMS
- Optional flash EPROM memory module available
- Key switch - RUN, REMote, PROGram
- Battery-backed RAM



SLC 5/04 Processors (Catalog No. 1747-L541, -L542, or -L543)

The SLC 5/04 processor provides the baseline functionality of the SLC 5/03 processor plus DH+ communication. Communication via DH+ is 3 to 12 times faster than DH-485, providing you with increased performance levels. In addition, the SLC 5/04 processor runs approximately 15% faster than the SLC 5/03 processor. The SLC 5/04 processor provides:

- Program memory sizes of 16K, 32K, or 64K
- High-speed performance — 0.90 ms/K typical
- Control of up to 4096 input and output points
- Online programming (includes runtime editing)
- Built-in DH+ channel, supporting:
 - High-speed communication (57.6K, 115.2K, and 230.4K baud)
 - Messaging capabilities with SLC 500, PLC-2®, PLC-5®, and PLC-5/250 processors
- Built-in RS-232 channel supporting DF1 Full-duplex, DF1 Half-Duplex Master/Slave for SCADA, DH-485 using a 1761-NET-AIC with a 1747-CP3 cable, and ASCII protocols
- Channel-to-channel (DH+ to DH-485) passthrough capability
- Channel-to-channel (DF1 Full-Duplex to DH+) passthrough
- Remote I/O passthrough from channel 0 (DF1) or channel 1 (DH+) using a 1747-SN or 1747-BSN remote I/O scanner module
- DeviceNet passthrough using 1747-SDN DeviceNet scanner module
- Built-in real-time clock/calendar
- 1 ms Selectable Timed Interrupt (STI)
- 0.50 ms Discrete Input Interrupt (DII)
- Advanced math features — trigonometric, PID, exponential, floating point, and the compute instruction
- Indirect addressing
- Flash PROM provides firmware upgrades without physically changing EPROMS
- Optional flash EPROM memory module available
- Key switch — RUN, REMote, PROGRAM (clear faults)
- Battery-backed RAM



SLC 5/05 Processors (Catalog No. 1747-L551, -L552, or -L553)

The SLC 5/05 processor provides identical control functionality as the SLC 5/04 processor using standard Ethernet communications instead of DH+. Ethernet communication takes place at 10 Mbps, providing you with a high-performance network for program upload/download, on-line editing, peer-to-peer messaging, data acquisition, and operator interface (e.g. RSView32). The variety of memory sizes allows you to closely match your application needs. The SLC 5/05 provides:

- Program memory sizes of 16K, 32K, or 64K
- High-speed performance - 0.90 ms/K typical
- Control of up to 4096 input and output points
- Online programming (includes runtime editing)
- Built-in 10Base-T Ethernet channel, supporting:
 - High-speed computer communication using TCP/IP
 - Messaging capabilities with SLC 5/05, PLC-5, and PLC-5/250 processors, 1785-ENET Ethernet interface module, and 1756-ENET Ethernet bridge, and other commercially available computer Ethernet modules
 - SNMP for standard Ethernet network management
 - BOOTP for optional dynamic IP address assignment
- Built-in RS-232 channel supporting DF1 Full-duplex, DF1 Half-Duplex Master/Slave for SCADA, DH-485 using a 1761-NET-AIC with a 1747-CP3 cable, and ASCII
- Ethernet to DH-485, channel-to-channel passthrough
- Ethernet to DF1, channel-to-channel passthrough
- Remote I/O passthrough from channel 0 (DF1 or DH485) or channel 1 (Ethernet) using a 1747-SN or 1747-BSN remote I/O scanner module
- DeviceNet passthrough using 1747-SDN DeviceNet scanner module
- Built-in real-time clock/calendar
- 1 ms Selectable Timed Interrupt (STI)
- 0.50 ms Discrete Input Interrupt (DII)
- Advanced math features — trigonometric, PID, exponential, floating point, and the compute instruction
- Indirect addressing
- Flash PROM provides firmware upgrades without physically changing EPROMS
- Optional flash EPROM memory module available
- Key switch - RUN, REMote, PROGram (clear faults)
- Battery-backed RAM



Processor Capabilities

The following table summarizes the specifications for the SLC 500 modular processors.

Specification	SLC 5/01	SLC 5/02	SLC 5/03	SLC 5/04	SLC 5/05
Memory Size (words)	L511: 1K L514: 4K	L524: 4K	L531: 8K L532: 16K	L541: 16K L542: 32K L543: 64K	L551: 16K L552: 32K L553: 64K
Power Supply Loading	350 mA at 5V dc 105 mA at 24V dc	350 mA at 5V dc 105 mA at 24V dc	500 mA at 5V dc 175 mA at 24V dc	1.0A at 5V dc 200 mA at 24V dc	1.0 mA at 5V dc 200 mA at 24V dc
Max. I/O Capacity	3940 Discrete inputs and outputs	4096 Discrete inputs and outputs	4096 Discrete inputs and outputs	4096 Discrete inputs and outputs	4096 Discrete inputs and outputs
Max. Local Chassis/Slots	3/30	3/30	3/30	3/30	3/30
On-board Communications	DH-485 Slave	DH-485	DH-485 & RS-232	DH+ & RS-232	Ethernet & RS-232
Programming	Programming Software or Hand-Held Terminal (HHT)		Programming Software		
Programming Instructions	52	71	107	107	107
Typical Scan Time ⁽¹⁾	8 ms/K	4.8 ms/K	1 ms/K	0.9 ms/K	0.9 ms/K
Program Scan Hold-up Time after Loss of Power	20 ms to 3s (dependent on power supply loading)				
Bit Execution (XIC)	4 μs	2.4 μs	0.44 μs	0.37 μs	0.37 μs
Clock/Calendar Accuracy	n/a	n/a	±54 seconds/month at +25°C (+77°F) ±81 seconds/month at +60°C (+140°F)		

(1) The scan times are typical for a 1K ladder logic program consisting of simple ladder logic and communication servicing. Actual scan times depend on your program size, instructions used, and the communication protocol.

System Protection Options

The following table summarizes the system protection options available for the SLC 500 processor family.

Types of Protection	SLC 5/01	SLC 5/02	SLC 5/03 and Higher
Password	•	•	•
Future Access (OEM Lock)	•	•	•
Program Owner	•	•	•
Program Files	NA	NA	•
Data Table Files	•	•	•
Memory Module Data File Overwrite	NA	NA	•
Memory Module Program Compare	NA	NA	•
Memory Module Write Protection	NA	NA	•
Force Protection	NA	NA	•
Keypad	NA	NA	•
Communication Channel Protection	NA	NA	•

Operating System Upgrade Kits

Kits are available to upgrade your SLC 5/03 and higher processors. By upgrading your processors's operating system, you can take advantage of 8 new programming instructions (including block transfers) and increased diagnostic capabilities.

Catalog Number	Product Description
1747-OS302	5/03 Firmware Upgrade Kit (includes 5 OS upgrade labels)
1747-OS401	5/04 Firmware Upgrade Kit (includes 5 OS upgrade labels)
1747-DU501	5/05 Firmware Upgrade Kit (includes 5 OS upgrade labels)
1747-RL302	5/03 Firmware Label Upgrade Kit (includes 10 OS upgrade labels)
1747-RL401	5/04 Firmware Label Upgrade Kit (includes 10 OS upgrade labels)
1747-RL501	5/05 Firmware Label Upgrade Kit (includes 10 OS upgrade labels)

Memory Modules

The following table summarizes the available memory back up options for the SLC 500 processors. EEPROM memory modules provide non-volatile memory back-up. Flash EPROMs (Flash Erasable Programmable Read Only Memory) combine the versatility of EEPROMs with the security of UVEPROMs.

	SLC 5/01	SLC 5/02	SLC 5/03	SLC 5/04	SLC 5/05
EEPROM	1747-M1 1747-M2	1747-M2	n/a	n/a	n/a
Flash	n/a	n/a	1747-M11 1747-M12	1747-M11 1747-M12	1747-M11 1747-M12

Program Storage Device

The 1747-PSD Program Storage Device simplifies PLC program backup and upgrade shipping issues for MicroLogix controllers and SLC 5/03 and higher processors. It allows you to backup PLC programs without using a computer or programming software. The PSD also enables you to make multiple copies of an installed program. OEMs can confidently ship program upgrades to end users for easy and low-cost installation at remote sites.

Features

- The 1747-PSD provides reliable storage of user programs. The device is designed for repetitive use; upload and download as you need to. It performs error checking prior to downloading a PLC program to ensure that the program is compatible with the target PLC.
- The PSD can be powered by either two AAA batteries or by an external power supply. A battery save feature shuts off power 30 seconds after the operation is completed. Stored programs are retained in Flash EPROM memory even if the batteries and power supply fail.
- The hand-held device is lightweight and very easy to use. Only minimal training should be needed. One red LED and one green LED provide instant status feedback. For ease of operation, all of the PSD functions can be accessed using one switch and one push button.
- Installation of the PSD is simple, using a standard RS-232, 9-pin, D-shell connector. The device attaches to the PLC with standard SLC 500 and MicroLogix cables.
- For maximum compatibility, the 1747-PSD can store the largest PLC programs of the SLC 500 and MicroLogix programmable controllers.

Specifications

Description	1747-PSD Specification
Compatible Programmable Controllers	SLC 5/03 and higher, MicroLogix 1000, 1200, and 1500
Memory Size	64K words maximum
Memory Type	Flash EPROM
Operating Power	(2) AAA batteries or power supply (7 to 30V dc, 250 mA maximum)
Compatible Cables	1747-CP3 and 1761-CBL-PM02 (not included)

Discrete I/O Modules

Our wide variety of input, output, and combination modules makes the SLC 500™ family the smart choice for all of your small PLC applications.

I/O modules are available in a wide variety of densities including 4-, 8-, 16-, and 32-point and can interface to AC, DC, and TTL voltage levels. Output modules are available with solid-state AC, solid-state DC, and relay contact type outputs. For added flexibility, combination modules are also available in 2-input/2-output, 4-input/4-output, and 6-input/6-output versions.

Designed and tested for industrial applications, our modules are of the highest quality. The modules feature input filtering, optical isolation, and built-in surge protection to enhance the reliability of operation in noisy industrial environments.

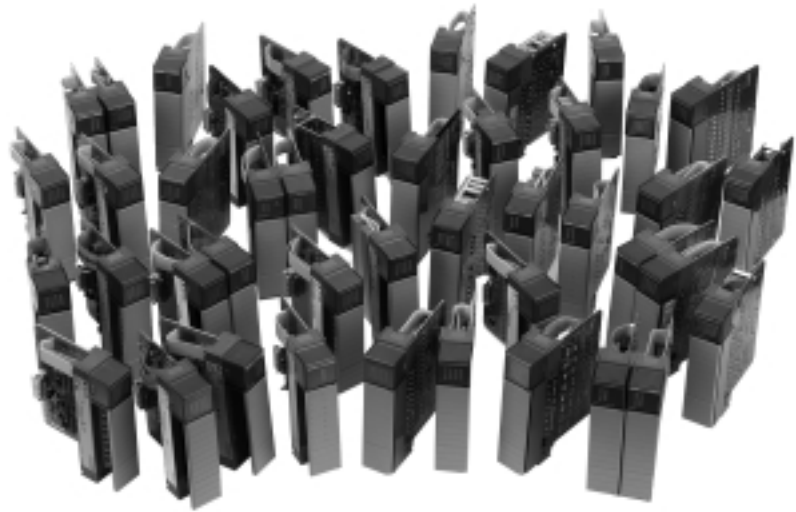

Features

Select I/O modules to exactly match your application with combination modules that allow you to have inputs and outputs in a single slot for efficient use of your chassis space.

High-density 32-point DC I/O and fast response DC inputs are available, allowing the SLC 500 to be applied in a broader spectrum of control applications

LEDs indicate the status of each I/O point, assisting you in troubleshooting. The LEDs illuminate when the proper signal is received at an input terminal, or when the processor applies power to an output terminal.

Terminal identification diagrams located on each module making terminal identification easier.

All modules feature optical isolation between digital and field circuits, resulting in increased noise immunity and limited damage to your system due to an electrical malfunction of the field wiring.

Solid-state output modules available with fusing and electronic protection, eliminating the need to replace modules damaged by short circuits and overloads.

Removable terminal blocks allow you to replace the module without rewiring it (not available on all modules). A matching color band is also provided on the front of the module to assist in matching the terminal block to the module.

Barrier-type terminal blocks provided on all modules to help prevent accidental shorting of field wiring.

Self-locking tabs secure the modules in the chassis, and no tools are necessary to either install or remove the modules to/from the chassis..

Discrete Input Modules



Catalog Number	Module Description	Voltage Category	Number of Inputs	Points Per Common	Power Supply Loading	
					5V dc	24V dc
1746-IA4	AC	100/120V ac	4	4	35 mA	0 mA
1746-IA8		100/120V ac	8	8	50 mA	0 mA
1746-IA16		100/120V ac	16	16	85 mA	0 mA
1746-IM4		200/240V ac	4	4	35 mA	0 mA
1746-IM8		200/240V ac	8	8	50 mA	0 mA
1746-IM16		200/240V ac	16	16	85 mA	0 mA
1746-IN16	AC/DC	24V ac/V dc	16	16	85 mA	0 mA
1746-IB8	Current Sinking DC	24V dc	8	8	50 mA	0 mA
1746-IB16		24V dc	16	16	85 mA	0 mA
1746-IB32		24V dc	32	8	50 mA	0 mA
1746-IC16		48V dc	16	16	85 mA	0 mA
1746-IH16		125V dc	16	16	85 mA	0 mA
1746-ITB16	Fast Response Current Sinking DC	24V dc	16	16	85 mA	0 mA
1746-IV8	Current Sourcing DC	24V dc	8	8	50 mA	0 mA
1746-IV16		24V dc	16	16	85 mA	0 mA
1746-IV32		24V dc	32	8	50 mA	0 mA
1746-IG16	Current Sourcing TTL	5V dc/TTL	16	16	140 mA	0 mA
1746-ITV16	Fast Response Current Sourcing DC	24V dc	16	16	85 mA	0 mA

Discrete Output Modules



Catalog Number	Module Description	Voltage Category	Number of Outputs	Points Per Common	Continuous Current per Point at 30°C (max.) ⁽¹⁾	Power Supply Loading	
						5V dc	24V dc
1746-OA8	AC	120/240V ac	8	4	1A	185 mA	0 mA
1746-OA16		120/240V ac	16	8	0.50A	370 mA	0 mA
1746-OAP12	High Current AC (short-circuit fuse protection)	120/240V ac	12	6	2.0A	370 mA	0 mA
1746-OB8	Current Sourcing DC	24V dc	8	8	1A	135 mA	0 mA
1746-OB16		24V dc	16	16	0.50A	280 mA	0 mA
1746-OB32		24V dc	32	16	0.1A	190 mA	0 mA
1746-OBP8	High Current Sourcing DC	24V dc	8	4	2.0A	135 mA	0 mA
1746-OBP16	High Current Sourcing DC (short-circuit fuse protection)	24V dc	16	16	1.5A	250 mA	0 mA
1746-OB6EI	Electronically Protected Current Sourcing DC	24V dc	6	Individually isolated	2.0A	46 mA	0 mA
1746-OB16E		24V dc	16	16	0.5A	280 mA	0 mA
1746-OB32E		24V dc	32	16	0.1A	190 mA	0 mA
1746-OV8	Current Sinking DC Output	24V dc	8	8	1A	135 mA	0 mA
1746-OV16		24V dc	16	16	0.50A	270 mA	0 mA
1746-OV32		24V dc	32	16	0.1A	190 mA	0 mA
1746-OVP16	High Current Sinking DC Output	24V dc	16	16	1.5A	250 mA	0 mA
1746-OG16	Current Sinking TTL Output	5V dc/TTL	16	16	0.02A	180 mA	0 mA
1746-OW4	AC/DC Relay	5 to 265V ac 5 to 125V dc	4	4	See page 16 relay chart	45 mA	45 mA
1746-OW8		5 to 265V ac 5 to 125V dc	8	4		85 mA	90 mA
1746-OW16		5 to 265V ac 5 to 125V dc	16	8		170 mA	180 mA
1746-OX8	Isolated AC/DC Relay	5 to 265V ac 5 to 125V dc	8	Individually isolated		85 mA	90 mA

(1) The current rating for most modules is derated linearly up to 60°C. All channels on a module may not be able to carry this current simultaneously. Refer to the SLC Discrete I/O Installation Instructions, publication 1746-6.3, for complete specifications.

Combination Discrete Input and Output Modules



Catalog Number	Module Description	Voltage Category	Number of Points	Points Per Common	Power Supply Loading	
					5V dc	24V dc
1746-IO4	AC Input	120V ac	2 inputs	2	30 mA	25 mA
	AC/DC Relay Output	5 to 265V ac 5 to 125V dc	2 outputs			
1746-IO8	AC Input	120V ac	4 inputs	4	60 mA	45 mA
		5 to 265V ac 5 to 125V dc	4 outputs			
1746-IO12	AC Input	120V ac	6 inputs	6	90 mA	70 mA
		5 to 265V ac 5 to 125V dc	6 outputs			
1746-IO12DC	DC Input	24 V dc	6 inputs	6	80 mA	60 mA
	AC/DC Relay Output	5 to 265V ac 5 to 125V dc	6 outputs			

Relay Output Contact Rating Chart

Type	Max. Volts	Amperes		Amps Continuous	Volts Amperes	
		Make	Break		Make	Break
Relay Contact Ratings for OW4, OW8, and OW16	240V ac	7.5A	0.75A	2.5A	1800 VA	180 VA
	120V ac	15.0A	1.50A			
	125V dc	0.22A		1.0A	28 VA	
	24V dc	1.2A		2.0A	28 VA	
Relay Contact Ratings for OX8	240V ac	15.0A	1.5A	5.0A	3600 VA	360 VA
	120V ac	30.0A	3.0A			
	125V dc	0.22A		1.0A	28 VA	
	24V dc	1.2A		2.0A	28 VA	

I/O Wiring

Terminals on the 4-, 8-, 12- and 16-point modules have self-lifting pressure plates that accept two 14 AWG (2mm²) wires. All 16-point I/O modules, 1746-OX8, -OB6EI, -OBP8, -OAP12, -IO12 and IO12DC are equipped with color-coded removable terminal blocks.

32-point I/O modules are equipped with a 40-pin, MIL-C-83503 type header and a removable wiring connector (1746-N3). The connector can be assembled with the wire type and length of your choice. Wiring the 16- and 32-point modules can also be done with a Catalog 1492 Interface module and pre-wired cable.



1492 Wiring System

The Bulletin 1492 Digital Programmable Controller Wiring System Product Line consists of IFMs (Interface Modules), Pre-Wired Cables and Ready-to-Wire Cables. These products aid in the installation of Allen-Bradley Programmable Controller I/O Modules. IFMs and pre-wired cables replace terminal blocks and up to 50% of the point-to-point wiring between the programmable controller and field devices. They are available for over 60 different 1746 SLC 500, 1756 ControlLogix, and 1771 PLC Digital I/O Isolated and Non-Isolated Modules. IFMs allow you to conveniently incorporate additional terminations, LED status indicators or over current protection into your I/O circuitry.

Features

- **Faster Installation Time:** Pre-wired cables have the I/O module terminal block or wiring arm already wired-up on one end and a cable connector on the other. No need to measure, cut, strip, label, and terminate 20 to 40 wires per I/O module.
- **Successful System Start-ups:** The pre-wired cables are 100% tested for continuity. No more crossed wires and loose connections between the I/O module and the terminal blocks on the DIN rail.
- **Simplified Troubleshooting:** IFMs with optional LED indicators provide the field-side status of the I/O circuitry. No more guesswork determining where a problem resides.
- **Reduced Panel Space:** Extra terminal, sensor, and fusible IFMs have terminals for connecting the I/O points. In addition, they contain common terminals that are used as power busses for field input and output devices. No additional terminal blocks are needed to provide power to the field-devices.
- **Quality-Looking Panel:** The pre-wired cables and IFMs organize your wiring and terminations for a consistent look to your panel. Pre-printed adhesive labels for the terminal wiring neatly identify field-side connections.

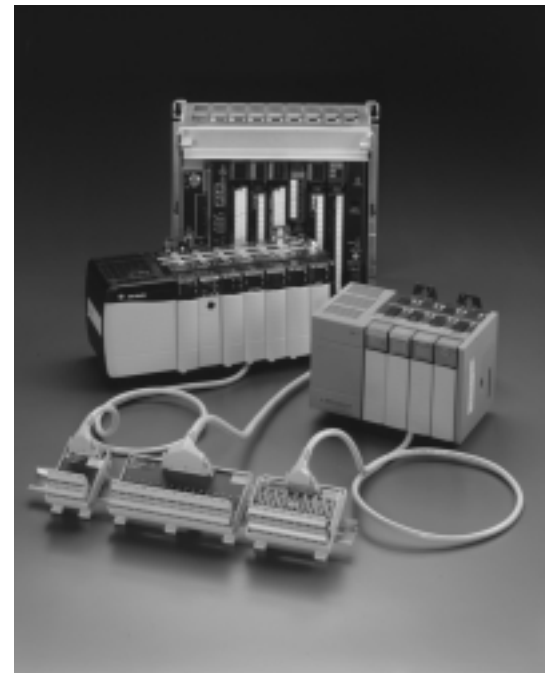

Analog I/O Modules

Small programmable controllers continue to be placed in process control applications demanding high densities, faster, more accurate measurement, and the flexibility to interface to a variety of temperature, pressure, and flow transducers.

The SLC 500 family offers multiple choices that broaden its control capabilities to serve these and other demanding applications.

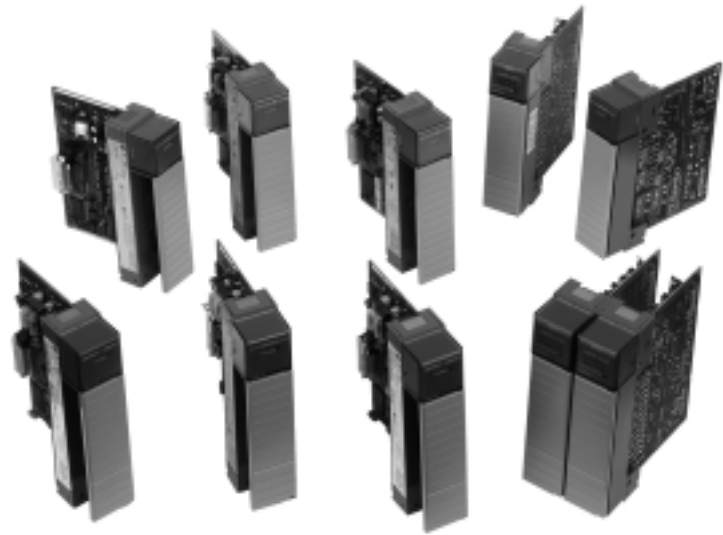

Features

- User-selectable inputs allow you to configure each input channel for a voltage or current signal from the sensor.
- High-resolution outputs that provide for precision control of analog outputs.
- Input filtering on modules provides high immunity to electrical noise or a fast input response for high-speed applications.
- Backplane isolation that isolates input signals from the backplane.
- Removable terminal blocks that allow you to replace a module quickly without removing the wiring.
- High-density modules that provide more efficient use of chassis space and lower cost per point.
- Diagnostic feedback that allows machine uptime to be increased and troubleshooting time reduced, with the help of diagnostic status bits for open-circuit and out-of-range detection. Channel status indicators and a module status indicator are also provided.
- Software configurable channels can be individually configured with the ladder program and can be re-configured without interrupting CPU operation. An easy-to-use bit configuration table allows the user to choose the input type, data format, filter frequency, and status data best suited to the application.

Analog Input Modules

Input Selection Chart

Catalog Number	Input Channels per Module	Backplane Current Draw	
		5V dc	24V dc
1746-NI4	4 differential, voltage or current selectable	25 mA	85 mA
1746-NI8	8 differential, voltage or current selectable	200 mA	100 mA
1746-NI16I	16 single-ended, current	125 mA	75 mA
1746-NI16V	16 single-ended, voltage	125 mA	75 mA



Analog Output Modules

Output Selection Guide

Catalog Number	Output Channels per Module	Backplane Current Draw	
		5V dc	24V dc
1746-NO4I	4 current outputs	55 mA	195 mA
1746-NO4V	4 voltage outputs	55 mA	145 mA



Combination Analog I/O Modules



Combination Selection Guide

Catalog Number	Input Channels per Module	Output Channels per Module	Backplane Current Draw	
			5V dc	24V dc
1746-NIO4I	2 differential, voltage or current selectable	2 current outputs	55 mA	145 mA
1746-NIO4V	2 differential, voltage or current selectable	2 voltage outputs	55 mA	115 mA
1746-FIO4I	2 differential, voltage or current selectable	2 current outputs	55 mA	150 mA
1746-FIO4V	2 differential, voltage or current selectable	2 voltage outputs	55 mA	120 mA

Input Characteristics

Specification	NI4	NI8	NIO4I	NIO4V	FIO4V	FIO4V	NI16I (Current only)	NI16V (Voltage only)
Number of inputs	4	8	2	2	2	2	16	16
Current/Voltage ranges							±10V dc (+10 to -10V dc; 0 to 5V dc; 1 to 5 V dc)	±20 mA (0 to 20 mA; 4 to 20 mA; 0 to 1 mA)
Step response	60 ms	selectable	60 ms		100 µs		selectable	
Overall Accuracy 0°C to +60°C (+32°F to +140°F)	±0.642%	±0.05% (I) ±0.10% (V)	±0.642%		±0.85%		±0.30%	±0.10%
Input A/D convertor	16-bit				12-bit		16-bit	
Input resolution (I)	1.22 µA/LSB	1 µA/bit	1.22 µA/LSB		9.76 µA/bit		1 µA	NA
Input resolution (V)	305.2 µV/LSB	1 mV/bit	305.2 µV/LSB		2.44 mV/LSB		NA	1 µV
Input coding (I)	±16, 384	depends on data format	±16, 384		0 to 2047		Depends on data format	
Input coding (V)	±32, 768		±32, 768		0 to 4095			
CMR at 60 Hz	105 dB	100 dB	105 dB		50 dB		100 dB	

Output Characteristics

Specification	FIO4I	NIO4I	N04I	FIO4V	NIO4V	N04V
Number of outputs	2	2	4	2	2	4
Output range	0 to 20 mA (0 to 20 mA; 4 to 20 mA)			0 to 10V dc (0 to 10V dc; 0 to 5V dc; 1 to 5V dc)		
Step Response	2.5 ms					
Overall Accuracy 0°C to +60°C (+32°F to +140°F)	±0.541%			±0.384%		
Output A/D convertor	14-bit					
Output Resolution (I)	2.56 µA/LSB			NA		
Output Resolution (V)	NA			1.22 mV/LSB		
Output coding 0 to 21 mA	0 to 32,764			NA		
Output coding ±10V dc	NA			±32,764		

Temperature Modules

Greatly enhance the temperature monitoring and control capabilities of your SLC 500 system with the 1746 temperature modules. Temperature modules eliminate the need for expensive thermocouple transmitters, providing a more economical means of addressing process applications in industries requiring temperature measurement and control.



1746-NT4, 1746-NT8, 1746-INT4 Thermocouple/mV Modules

Features

- 1746-NT4 and -NT8 modules provide a choice of four filter frequencies, permitting you to select input noise filtering appropriate to the application and surrounding environment. Either or both 50 Hz and 60 Hz noise can be filtered from the input signal for greater noise rejection and resolution. The 250 Hz filter provides minimum noise rejection and is best suited for mV input applications where fast response to step changes is required.
- All modules provide cold-junction temperature compensation (CJC), fully integrated into the removable terminal block, as a means of retaining thermocouple input signal accuracy. Two thermistor assemblies located at each end of the terminal block measure and compensate for the absolute temperature of the reference junction.
- 1746-NT4 and -NT8 provide auto-calibration functions to compensate for module component drift. This guarantees module accuracy and saves valuable time.
- All modules provide fault diagnostics to check for open circuits or out-of-range values, then indicates operational problems on status LEDs. Four channel status LEDs and diagnostic bits signal you if input channel data is out of range or if an open-circuit condition is present. Channel configuration validity is also checked. In addition, a module status LED differentiates recoverable channel errors from more serious module-related problems, saving you troubleshooting time.
- The high-density 1746-NT8 module is ideal for applications with a large number of thermocouple inputs.
- The 1746-INT4 module provides 1000V peak channel-to-channel isolation (150V ac continuous).

Thermocouple Temperature Ranges

Thermocouple Input	°C Temperature Range	°F Temperature Range	Accuracy Max. Error at +25°C (+77°F)
Type J	-210°C to 760°C	-346°F to 1400°F	±1.06°C (NT4) ±1.4°C (NT8) ±1.6°C (INT4)
Type K	-270°C to 1370°C	-454°F to 2498°F	±1.72°C (NT4) ±1.5°C (NT8) ±3.8°C (INT4)
Type T	-270°C to 400°C	-454°F to 752°F	±1.43°C (NT4) ±1.3°C (NT8) ±2.05°C (INT4)
Type E	-270°C to 1000°C	-454°F to 1832°F	±0.72°C (NT4) ±1.0°C (NT8) ±2.4°C (INT4)
Type N	0°C to 1300°C	32°F to 2372°F	±1.39°C (NT4) ±1.3°C (NT8) ±1.79°C (INT4)
Type R	0°C to 1768°C	32°F to 3214°F	±3.59°C (NT4) ±3.6°C (NT8) ±2.23°C (INT4)
Type S	0°C to 1768°C	32°F to 3214°F	±3.61°C (NT4) ±3.4°C (NT8) ±2.38°C (INT4)
Type B	300°C to 1820°C	572°F to 3308°F	±3.12°C (NT4) ±2.7°C (NT8) ±3.83°C (INT4)
Type C	0°C to 2317°C	32°F to 4201°F	±2.28°C (INT4)
Type D	0°C to 2317°C	32°F to 4201°F	±2.52°C (INT4)

DC Millivolt Input Ranges

Input Type	Range	Accuracy, Max. Error at 25°C (+77°F)
±50 mV	-50 mV dc to +50 mV dc	50 µV
±100 mV	-100 mV dc to +100 mV dc	50 µV

Specifications

Specification	NT4	INT4	NT8
Number of Channels	4	4	8
Backplane Current Draw	60 mA at 5V dc 40 mA at 24V dc	110 mA at 5V dc 85 mA at 24V dc	120 mA at 5V dc 70 mA at 24V dc
Cold-Junction Compensation	Accuracy ±1.5°C, 0°C to 85°C	Accuracy ±1.5°C, 0°C to 70°C	Accuracy ±1.72°C, -25°C to +105°C
Temperature Scale Resolution (selectable)	1°C or 1°F 0.1°C or 0.1°F		
Millivolt Scale Resolution (selectable)	0.1 millivolt 0.01 millivolt (mV)		
Open-Circuit Detection (selectable)	Upscale	Upscale, downscale, or zero	Upscale, downscale, zero, or disabled
Input Step Response	Selectable Filter	600 mS	Selectable Filter

1746-NR4 and -NR8 RTD Resistance Input Modules

Features

These modules provide a choice of four filter frequencies, permitting you to select input noise filtering appropriate to the application and surrounding environment. Either or both 50Hz and 60Hz noise can be filtered from the input signal for greater noise rejection and resolution. For applications where system response speed is critical, minimum filtering can be selected to reduce the time it takes a step change at the input to be made available to the SLC 500 controller.

These modules require no user calibration. The 1746-NR4 module's channels initiate a calibration cycle at power-up, on channel configuration, or on your command to compensate for module component drift. The 1746-NR8 initiates a calibration cycle at power-up or at user-enabled periodic intervals (default = every 5 minutes). This enhances module accuracy and saves valuable service time and money.

Provides fault diagnostics to check for open circuits, short circuits or out-of-range values, then indicates operational problems on status LEDs. Channel status LEDs and diagnostic bits signal you if input channel data is out of range or if an open-circuit or short-circuit condition is present. Channel configuration validity is also checked. In addition, a module status LED differentiates recoverable channel errors from more serious module-related problems, saving you troubleshooting time and money.



Specifications

Description	1746-NR4 Specification	1746-NR8 Specification
Backplane Current Draw	50 mA at 5V dc, 50 mA at 24V dc	100 mA at 5V dc, 70 mA at 24V dc
Temperature Scale (Selectable)	1°C or 1°F and 0.1°C or 0.1°F	
Resistance Scale (Selectable)	1Ω or 0.1Ω for all resistance ranges; or 0.1Ω or 0.01Ω for 150Ω potentiometer.	
Input Step Response	Selectable Filter: <ul style="list-style-type: none"> • 10 Hz • 50 Hz • 60 Hz • 250 Hz 	Selectable Filter: <ul style="list-style-type: none"> • 28 Hz • 50/60 Hz • 800 Hz • 6400 Hz
RTD Excitation Current	Two current values are user-selectable: <ul style="list-style-type: none"> • 0.5 mA⁽¹⁾ • 2.0 mA⁽²⁾ 	Two current values are user-selectable: <ul style="list-style-type: none"> • 0.25 mA⁽¹⁾ • 1.0 mA⁽²⁾
Open-Circuit or Short-Circuit Method	Zero, upscale or downscale	
Maximum Cable Impedance	25Ω maximum per 1000 feet	
Maximum Wire Size	Two 24 AWG wires per terminal	One 24 AWG wire per terminal
Calibration	Auto-calibration at power-up and when a channel is enabled	Auto-calibration at power-up and user-enabled periodic calibration
Channel-to-Channel Isolation	None	±5V
Input-to-Backplane Isolation	500V ac for 1 minute	
Common Mode Voltage Separation	±1V maximum	

Recommended for use with higher resistance ranges for both RTDs and direct resistance inputs (1000W RTDs and 3000W resistance input). Contact the RTD manufacturer for recommendations. Cannot use for 10W Copper RTD.

Must use for 10W Copper RTD. Recommended to use for all other RTD and direct resistance inputs, except 1000W RTDs and 3000W resistance input ranges. Contact RTD manufacturer for recommendations.

RTD Temperature Range and Accuracy Specifications

RTD Type		1746-NR4				1746-NR8			
		0.5 mA Excitation		2.0 mA Excitation		0.25 mA Excitation		1.0 mA Excitation	
		Temp. Range	Acc.	Temp. Range	Acc. ⁽¹⁾	Temp. Range	Acc. ⁽¹⁾	Temp. Range	Acc. ⁽¹⁾
Platinum (385)	100Ω	-200°C to +850°C (-328°F to +1562°F)	±1.0°C (±2.0°F)	-200°C to +850°C (-328°F to +1562°F)	±0.5°C (±0.9°F)	-200°C to +850°C (-328°F to +1562°F)	±0.5°C (±0.9°F)	-200°C to +850°C (-328°F to +1562°F)	±0.7°C (±1.3°F)
	200Ω	-200°C to +850°C (-328°F to +1562°F)	±1.0°C ⁽²⁾ (±2.0°F)	-200°C to +850°C (-328°F to +1562°F)	±0.5°C (±0.9°F)	-200°C to +850°C (-328°F to +1562°F)	±0.6°C (±1.1°F)	-200°C to +850°C (-328°F to +1562°F)	±0.7°C (±1.3°F)
	500Ω	-200°C to +850°C (-328°F to +1562°F)	±0.6°C (±1.1°F)	-200°C to +850°C (-328°F to +1562°F)	±0.5°C (±0.9°F)	-200°C to +850°C (-328°F to +1562°F)	±0.7°C (±1.3°F)	-200°C to +370°C (-328°F to +698°F)	±0.5°C (±0.9°F)
	1000Ω	-200°C to +850°C (-328°F to +1562°F)	±0.6°C (±1.1°F)	-200°C to +240°C (-328°F to +464°F)	±0.5°C (±0.9°F)	-200°C to +850°C (-328°F to +1562°F)	±1.2°C (±2.2°F)	-200°C to +50°C (-328°F to +122°F)	±0.4°C (±0.7°F)
Platinum (3916)	100Ω	-200°C to +630°C (-328°F to +1166°F)	±1.0°C ⁽²⁾ (±2.0°F)	-200°C to +630°C (-328°F to +1166°F)	±0.4°C (±0.7°F)	-200°C to +630°C (-328°F to +1166°F)	±0.4°C (±0.7°F)	-200°C to +630°C (-328°F to +1166°F)	±0.6°C (±1.1°F)
	200Ω	-200°C to +630°C (-328°F to +1166°F)	±1.0°C ⁽²⁾ (±2.0°F)	-200°C to +630°C (-328°F to +1166°F)	±0.4°C (±0.7°F)	-200°C to +630°C (-328°F to +1166°F)	±0.5°C (±0.9°F)	-200°C to +630°C (-328°F to +1166°F)	±0.6°C (±1.1°F)
	500Ω	-200°C to +630°C (-328°F to +1166°F)	±0.5°C (±0.9°F)	-200°C to +630°C (-328°F to +1166°F)	±0.4°C (±0.7°F)	-200°C to +630°C (-328°F to +1166°F)	±0.6°C (±1.1°F)	-200°C to +370°C (-328°F to +698°F)	±0.4°C (±0.7°F)
	1000Ω	-200°C to +630°C (-328°F to +1166°F)	±0.5°C (±0.9°F)	-200°C to +230°C (-328°F to +446°F)	±0.4°C (±0.7°F)	-200°C to +630°C (-328°F to +1166°F)	±0.9°C (±1.6°F)	-200°C to +50°C (-328°F to +122°F)	±0.3°C (±0.6°F)
Copper (426)	10Ω	Not Allowed		-100°C to +260°C (-148°F to +500°F)	±0.6°C (±1.1°F)	-100°C to +260°C (-148°F to +500°F)	±0.5°C (±0.9°F)	-100°C to +260°C (-148°F to +500°F)	±0.8°C (±1.4°F)
Nickel (618)	120Ω	-100°C to +260°C (-148°F to +500°F)	±0.2°C (±0.4°F)	-100°C to +260°C (-148°F to +500°F)	±0.2°C (±0.4°F)	-100°C to +260°C (-148°F to +500°F)	±0.2°C (±0.4°F)	-100°C to +260°C (-148°F to +500°F)	±0.2°C (±0.4°F)
Nickel (672)	120Ω	-80°C to +260°C (-112°F to +500°F)	±0.2°C (±0.4°F)	-80°C to +260°C (-112°F to +500°F)	±0.2°C (±0.4°F)	-80°C to +260°C (-112°F to +500°F)	±0.2°C (±0.4°F)	-80°C to +260°C (-112°F to +500°F)	±0.2°C (±0.4°F)
Nickel/ Iron (518)	604Ω	-100°C to +200°C (-148°F to +392°F)	±0.3°C (±0.5°F)	-100°C to +200°C (-148°F to +392°F)	±0.3°C (±0.5°F)	-200°C to +200°C (-328°F to +392°F)	±0.3°C (±0.5°F)	-200°C to +170°C (-328°F to +338°F)	±0.3°C (±0.5°F)

(1) The accuracy values assume that the module was calibrated within the specified temperature range of 0°C to 60°C (32°F to 140°F).

(2) Module accuracy, using 100W or 200W platinum RTDs with 0.5 excitation current, depends on the following criteria:

- (a) Module accuracy is ±0.6°C after you apply power to the module or perform an autocalibration at 25°C (77°F) ambient with module operating temperature at 25°C (77°F).
- (b) Module accuracy is ±(0.6°C + DT x 0.034°C/°C) after you apply power to the module or perform an autocalibration at 25°C (77°F) ambient with the module operating temperature between 0°C to 60°C (32°F to 140°F). - where DT is the temperature difference between the actual operating temperature of the module and 25°C (77°F) and 0.034°C/°C is the temperature drift shown in the table above for 100W or 200W platinum RTDs.
- (c) Module accuracy is ±1.0°C after you apply power to the module or perform an autocalibration at 60°C (140°F) ambient with module operating temperature at 60°C (140°F).

Resistance Input Specifications

Resistance		0.5 mA Excitation			2.0 mA Excitation			Resolution	Repeatability
		Resistance Range	Accuracy ⁽¹⁾	Temperature Drift	Resistance	Accuracy ⁽¹⁾	Temperature Drift		
1746-NR4	150Ω	0Ω to 150Ω	±0.2Ω	±0.006Ω/°C (±0.003Ω/°F)	0Ω to 150Ω	±0.15Ω	±0.004Ω/°C (±0.002Ω/°F)	0.01Ω	±0.04Ω
	500Ω	0Ω to 500Ω	±0.5Ω	±0.014Ω/°C (±0.008Ω/°F)	0Ω to 500Ω	±0.5Ω	±0.014Ω/°C (±0.008Ω/°F)	0.1Ω	±0.2Ω
	1000Ω	0Ω to 1000Ω	±1.0Ω	±0.029Ω/°C (±0.016Ω/°F)	0Ω to 1000Ω	±1.0Ω	±0.029Ω/°C (±0.016Ω/°F)	0.1Ω	±0.2Ω
	3000Ω	0Ω to 3000Ω	±1.5Ω	±0.043Ω/°C (±0.024Ω/°F)	0Ω to 1900Ω	±1.5Ω	±0.043Ω/°C (±0.024Ω/°F)	0.1Ω	±0.2Ω
Resistance		0.25 mA Excitation		Temperature Drift	1.0 mA Excitation		Temperature Drift	Resolution	Repeatability
		Resistance Range	Accuracy ⁽¹⁾		Resistance Range	Accuracy ⁽¹⁾			
1746-NR8	150Ω	0Ω to 150Ω	±0.2Ω	±0.004Ω/°C (±0.002Ω/°F)	0Ω to 150Ω	±0.15Ω	±0.003Ω/°C (±0.002Ω/°F)	0.01Ω	±0.04Ω
	500Ω	0Ω to 500Ω	±0.5Ω	±0.012Ω/°C (±0.007Ω/°F)	0Ω to 500Ω	±0.5Ω	±0.012Ω/°C (±0.007Ω/°F)	0.1Ω	±0.2Ω
	1000Ω	0Ω to 1000Ω	±1.0Ω	±0.025Ω/°C (±0.014Ω/°F)	0Ω to 1000Ω	±1.0Ω	±0.025Ω/°C (±0.014Ω/°F)	0.1Ω	±0.2Ω
	3000Ω	0Ω to 3000Ω	±1.5Ω	±0.040Ω/°C (±0.023Ω/°F)	0Ω to 1200Ω	±1.2Ω	±0.040Ω/°C (±0.023 /°F)	0.1Ω	±0.2Ω

(1) The accuracy values assume that the module was calibrated within the specified temperature range of 0°C to 60°C (32°F to 140°F).

Counting, Positioning and Motion Modules

26

The Allen-Bradley SLC 500 counting, positioning, and motion modules are well suited to basic motion control, and offer a wide variety of control application solutions. Whether you have positioning applications, single-axis or servo control, or high-speed registration, there is an SLC 500 module to meet your needs.



1746-HSCE High-Speed Counter Module

The High-Speed Counter Module provides bidirectional counting of high-speed inputs from quadrature encoders and various high-speed switches. This single channel module accepts input pulse frequencies of up to 50k Hz, allowing precise control of fast motions. This module is compatible with the SLC 5/02 and higher processors.

In addition to providing an Accumulated Count, the module provides Rate Measurement indicating the pulse frequency in Hz. The Rate Measurement is determined by accumulating input pulses over a fixed period of time. The dynamically configurable Rate Period ranges from 10 milliseconds to 2.55 seconds.

Features

- Three modes of operation: Range, Rate, and Sequencer — Allows you to select the best mode to fit your application.
- Four on-board open collector outputs — Allows control independent of the SLC processor scan by the module.



Specifications

Description	Specification
Inputs	1 count input 5V, 12V, or 24V dc
Max. Input Frequency	50 KHz for range, 32 KHz for rate, 50 KHz for sequencer
Max. Counts	16-bit, $\pm 32,768$
Outputs	4 open-collector outputs: 5V, 12V, or 24V dc; Maximum current: 125mA at 30°C
Module Update Time	Range Mode: 3.9 ms; Rate Mode: 70 ms + rate; Sequencer Mode: 1.8 ms
Backplane Current draw	32 mA at 5V dc

1746-HSCE2 Multiple Channel High-Speed Counter and Encoder Module

The 1746-HSCE2 is a 24-bit high-speed, multi-channel counter that directly interfaces with incremental encoders and other high-speed input sensors. The module accepts bi-directional input pulse frequencies of up to 1 MHz. For faster throughput time, the module has four on-board outputs that are controlled independently of the output scan. The status of four “soft outputs” can also be made available to the SLC backplane for control of additional outputs.

The module supports three operating modes that provide two-, three-, or four-channel operation. It is configurable for up to two quadrature encoder inputs and up to four pulse inputs. System performance is enhanced with the module’s ability to accept control adjustments while it is actively counting pulses. In addition to monitoring an encoder market pulse, the Z/gate input channel can be used for storing, holding, and resetting count data.



Features

- High-speed counting applications — Frequency response up to 1 MHz and 24-bit count capability.
- Configuration for ring or linear counting, rate calculation, output control by count range, output control by rate range, and pulse gating.
- Configuration flexibility — Easy-to-use bit configuration tables allow the user to choose the counter functionality best suited for the application
- Suitable for remote applications

Specifications

Description	Specification
Inputs	2 sets of $\pm A$, $\pm B$, $\pm Z$ inputs; interface capability for 2 quadrature encoders or 4 pulse inputs; differential or single-ended 4.2 to 12V dc, 10 to 30V dc; jumper selectable for each A, B, Z channel
Frequency Response	250 KHz at X4, 500 KHz at X2, 1 MHz for all other
Max. Counts	$\pm 8,388,607$ (24-bit) with SLC 5/03 and higher processors, or 1747-ACN15/-ACNR15 remote chassis (Class 4) $\pm 32,768$ (16-bit) with SLC 5/01, 5/02, and 1747-ASB in remote chassis (Class 1)
Outputs	4 outputs, 24V dc. Max. current 1A at 40°C
I/O Throughput to Backplane and On-board Outputs	300 to 1500 μ s: 700 μ s typical
Backplane Current draw	250 mA at 5V dc

1746-HSTP1 Stepper Control Module

The 1746-HSTP1 Stepper Control module is a single-axis stepper controller. Operating with a variety of SLC 500 processors, this single-slot module is capable of providing up to 250 KHz pulse train output for micro-stepping applications.

Use this module for open-loop stepper applications with single-axis control requirements. The SLC's data table contains all the program and configuration information. The module also has the ability to interface directly with a quadrature encoder to monitor position. The five LED's on the front of the module allow you to quickly determine module status and error conditions.

The module is programmed and commissioned using RSLogix 500 programming software. For a given move profile, you program the distance, acceleration, deceleration, and velocity. With +5V or +15V encoders that provide differential feedback, the module interfaces directly to accept position information.



Features

- Over ±8,000,000 counts of absolute positioning for accurate and precise positioning of a mechanism.
- Compatibility with translators requiring a pulse train/direction input or a CW/CCW pulse train input.
- Accepts position feedback from a single encoder for closed loop operation.
- Programmable modes of operation eliminates the need to set DIP switches.
- Five LEDs provide quick status information and troubleshooting help.
- Built-in loop back diagnostics permits monitoring of the pulse train commands.

Specifications

Description	Specification
Inputs	5V dc differential encoder or 12/24V dc single ended auxiliary
Max. Input Frequency	250 KHz
Outputs	Digital output for translator
Module Update Time	4 ms
Backplane Current draw	300 mA at 5V dc

1746-HSRV Servo Control Module

The 1746-HSRV Servo Control module is a single-axis, closed-loop servo controller. The single-slot module can be operated with a variety of SLC 500 processors with block execution independent of the scan time of the processor. The system is programmed with RSLogix 500 programming software since ladder logic controls all of the motion. For fast and accurate control, the module monitors encoder feedback up to 300 KHz.

Complicated moves are accomplished using blended motion profiles stored in the module's internal memory and can be executed repeatedly. The profiles are stored as a series of absolute moves, and additional moves or homing operations can be performed between blended moves. The module can automatically reset the absolute position when an encoder marker pulse is detected.



Features

- Four fast I/O points — Controlled by the IMC 110 system, saving valuable throughput time.
- +10V dc signal - Provides an interface to most servo drives.
- 5 ms Servo Loop Closure Rate - Provides a high degree of accuracy and system response.
- Termination Panel Interface - Provides a wiring connection for fast I/O, E-stop, power supplies, drive command and encoder feedback.

Specifications

Description	Specification
Inputs	3 general purpose local fast inputs
Max. Input Frequency	300 KHz at 0 degree quadrature error
Outputs	1 general purpose local fast output
Module Update Time	2 ms
Backplane Current draw	300 mA at 5V dc

Application Specific Modules

The SLC 500 family offers a variety of modules for specialty applications which all fit directly into the SLC chassis.



1746-BAS, 1746-BAS-T BASIC Modules

The 1746-BAS and 1746-BAS-T modules, which are programmed using the BASIC language, add additional functionality to any SLC 500 application.

The BASIC modules can be programmed with the BASIC development software PBASE. This software, which runs on computers running MS-DOS, facilitates program creation, editing, translating, debugging, uploading, and downloading of BASIC programs to the BASIC modules. Used together, the BASIC modules and the BASIC development software provide a powerful solution to your data collection and foreign device interface applications.

Features

- Familiar programming language, programs in a subset of the Intel 52 BASIC language.
- Communication to a variety of operator interfaces using two serial ports that can be configured to support RS-232/423, RS-422, and RS-485.
- 24K bytes of battery-backed RAM and optional 8K or 32K byte non-volatile memory modules are provided for data collection.
- DF1 protocol can be implemented in full-duplex and half-duplex slave modes for connection to modems.
- High-performance (4x faster) BAS-T module available for applications requiring fast program execution.
- Communication to an SLC 500 processor can take place across the 1746 I/O backplane or on the DH-485 network through the module's DH-485 port.

Specifications

Specification	BAS	BAS-T
Memory Size	24K bytes battery backed RAM	
Optional Memory Modules	8K byte and 32K byte EEPROM 8K byte and 32K byte UVPRM	
Number of Ports	3	
Port Configuration	RS-232, RS-422, RS-485, DH-485	
Backplane Current Draw	150 mA at 5V dc, 40 mA at 24V dc	
Program Execution Speed	N/A	4 times faster than BAS

1747-PCI Computer Bus Interface Module/System

The 1746-PCI computer bus interface module/system consists of a PCI Bus card for a personal computer and a chassis interface module for an SLC chassis. This system provides users the advantage of high-speed local I/O by linking a soft programmable controller to the 1746 I/O chassis over the standard PCI bus. The PCI bus is included in most personal computers manufactured today.

Features

- High-speed local I/O performance for PC-based solutions
- Seamless integration with Allen-Bradley SoftLogix 5 Controller
- Connectivity to field proven 1746 I/O
- Additional battery-backed SRAM memory for user application

1746-BLM Blow Molding Module

The Blow Molding module is an intelligent I/O module that can provide a maximum of 4 axes of closed-loop parison control on most types of blow molding machines. You can use multiple modules on machines with more than four heads. Configurations include accumulator push-out control and three parison axis, and two accumulator push-outs and two parison axis. The module is designed to work in a variety of applications including accumulator machines, continuous extrusion machines, and reciprocating screw machines. The module performs its servo control task independently from the processor, but receives its configuration and run-time information from the processor.

Specifications

Description	Specification
Number of Inputs/Outputs	4 analog inputs and 4 analog outputs
Resolution	14 bit
Range	+/- 10V dc
Excitation Output	+/- 10V dc at 2 mA
Backplane Current Load	1 A at 5V dc

1746-BTM Barrel Temperature Module

The temperature control module is an intelligent I/O module that can provide a maximum of 4 PID loops for temperature control. The module has 4 analog thermocouple (TC) inputs. Each input functions as the process variable (PV) for a PID loop. The PID algorithm and tuning-assisted-process (TAP) algorithm are performed on the module for each of the loops. The control-variable (CV) output of each loop, either analog output or time-proportioned output (TPO), is sent from the module to the SLC data table. Your application ladder logic must access the CV value in the data table and send the analog or TPO data to an output module to close the loop.

Specifications

Description	Specification
Number of Inputs/Outputs	4 temperature inputs for PID heat/cool loops
Resolution	16-bit resolution or 15-bit plus sign bit
Data Format	16-bit signed integer (natural binary)
Backplane Current Load	110 mA at 5V dc, 85 mA at 24V dc

Communication Choices

Rockwell Automation offers many control and communication media products that help you integrate plant operations. These products, combined with other vendors' products, provide plant-wide solutions that meet your control system and business needs.

There are three main levels of network:

The Information Level — allows various IS, MES and Data Archiving systems access to plant floor data for financial, quality, manufacturing, and development purposes.

The Control Level — provides deterministic, repeatable performance for I/O, programming and peer-to-peer communications, while spanning the entire manufacturing process from raw materials to finished product.

The Device Level — allows users to reduce hard wiring, save installation time and costs, and gain valuable diagnostics from the various sensors, actuators, and other devices connecting to the control system.

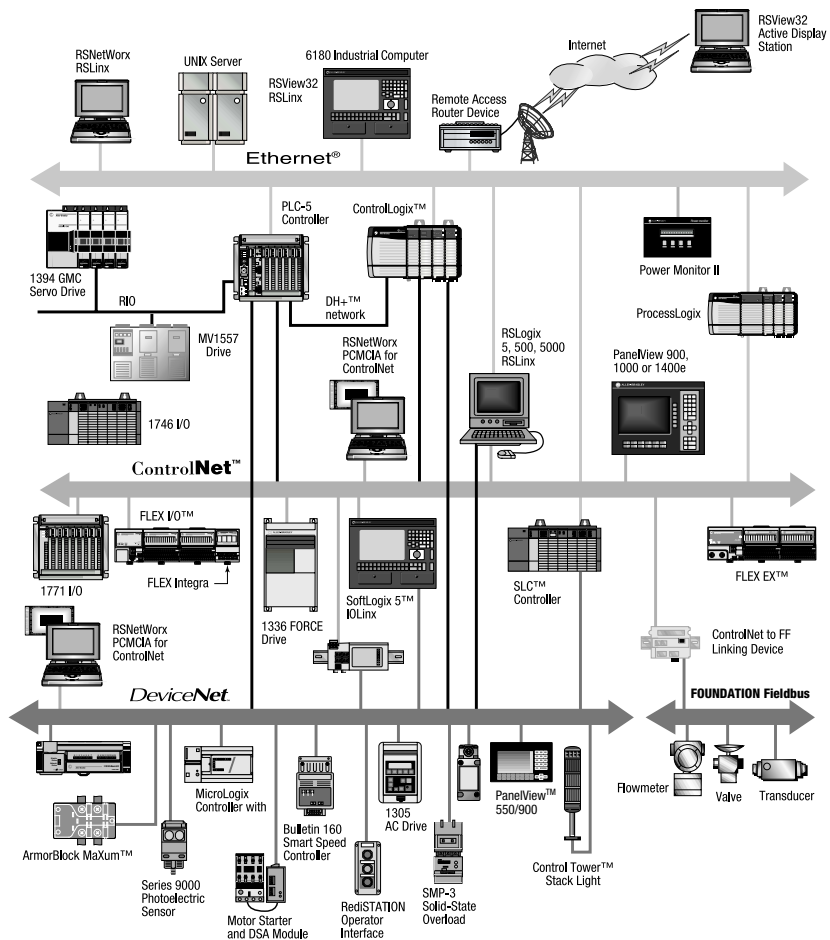

Choosing your Network

The SLC 500 provides a connection to all three levels of network, choose the network(s) that best meet your needs:

If your application requires:	Use this network	Type:
<ul style="list-style-type: none"> High-speed data transfer between information systems and/or a large quantity of controllers Internet/Intranet connection Program maintenance 	Ethernet network	Information Network
<ul style="list-style-type: none"> High-speed transfer of time-critical data between controllers and I/O devices Deterministic and repeatable data delivery Program maintenance Media redundancy or intrinsic safety options 	ControlNet	Control and Information network
<ul style="list-style-type: none"> Connections of low-level devices directly to plant floor controllers, without the need to interface them through I/O modules More diagnostics for improved data collection and fault detection Less wiring and reduced start up time than traditional, hard wired systems 	DeviceNet network	Device network
<ul style="list-style-type: none"> Plant-wide and cell-level data sharing with program maintenance 	Data Highway Plus (DH+) and DH-485	Information network
<ul style="list-style-type: none"> Connections between controllers and I/O adapters Distributed controllers so that each has its own I/O and communicates with a supervisory controller 	Universal Remote I/O	Control network
<ul style="list-style-type: none"> Modems Messages that send and receive ASCII characters to or from devices such as ASCII terminals, bar code readers, message displays, weigh scales, or printers Supervisory control and data acquisition 	Serial network	Serial network

Ethernet Network

The TCP/IP Ethernet network is a local-area network designed for the high-speed exchange of information between computers and related devices. With its high bandwidth (10 Mbps to 100 Mbps), an Ethernet network allows many computers, controllers, and other devices to communicate over vast distances.

At the information layer, an Ethernet network provides enterprise-wide systems access to plant-floor data.

With an Ethernet network you have many possibilities because you can maximize communication between the great variety of equipment available from vendors. TCP/IP is the protocol used by the Internet. Ethernet connectivity for the SLC 500 is provided by the SLC 5/05 processor; see page 10 for more details.



ControlNet Network

The ControlNet network is an open, high-speed deterministic network used for transmitting time-critical information. It provides real-time control and messaging services for peer-to-peer communication. As a high-speed link between controllers and I/O devices, a ControlNet network combines the capabilities of existing Universal Remote I/O and DH+ networks. You can connect a variety of devices to a ControlNet network, including personal computers, controllers, operator interface devices, drives, I/O modules, and other devices with ControlNet connections.

At the control layer, a ControlNet network combines the functionality of an I/O network and a peer-to-peer messaging network. This open network provides the performance required for critical control data, such as I/O updates and controller-to-controller interlocking. ControlNet also supports transfers of non-critical data, such as program uploads, downloads, and messaging.

ControlNet connectivity for the SLC 500 is provided by the following interfaces:

1747-KFC15 ControlNet Messaging Module

The 1747-KFC15 module provides unscheduled ControlNet network connection for SLC 5/03 and higher processors. With unscheduled messaging, the SLC controller program can send peer-to-peer messages or be accessed and edited over the ControlNet network using RSLogix 500 programming software.

Features

- 4-digit, 7-segment display for node address and module status
- Node address set via rotary switches (in decimal)
- RS-232 KFC-to-SLC cable included
- RJ-45 Network Access Port
- Media redundancy (Dual BNC connectors)
- Module powered directly from the SLC chassis backplane
- Software upgradable via ControlFlash

1747-SCNR ControlNet Scanner

The 1747-SCNR scanner module provides a scheduled ControlNet network connection for SLC 5/03 and higher processors. With scheduled messaging, the SLC processor can control I/O events in real-time on the ControlNet network.

1747-ACN15 and -ACNR15 ControlNet Adapters

The 1747-ACN15 and 1747-ACNR15 adapter modules provide the capability for up to three 1746 chassis (30 slots) of discrete, analog and specialty I/O modules to produce/consume scheduled I/O to a ControlNet network. These modules have been designed to provide both scheduled and unscheduled ControlNet network connections for 1746 I/O.



Features

- Optional media redundancy (dual BNC connectors) available with ACNR
- Compatible with all 1746 discrete, analog, and specialty modules except those requiring G file configuration, e.g. 1747-SN
- Supports connections to individual modules or chassis connections to a group of discrete modules
- Software upgrade via Control Flash

DeviceNet Network

The DeviceNet network is an open, low-level communication link that provides connections between simple industrial devices (such as sensors and actuators) and high-level devices (such as controllers). Based on standard Controller Area Network (CAN) technology, this open network offers inter-operability between like devices from multiple vendors. A DeviceNet network reduces installation costs, start-up/commissioning time, plus system and machine down time.

The DeviceNet network provides:

- Inter-operability: simple devices from multiple vendors that meet DeviceNet standards are interchangeable
- Common network: an open network provides common, end-user solutions, and reduces the need to support a wide variety of device networks
- Lower maintenance costs: you can remove and replace devices without disrupting other devices
- Cost-effective wiring: one wire supplies communications and 24V power networked device installation is more cost-effective than traditional I/O wiring

DeviceNet connectivity for the SLC 500 is provided by the following interfaces:

1747-SDN DeviceNet Scanner Module

The 1747-SDN DeviceNet Scanner modules acts as an interface between DeviceNet devices and SLC 5/02 or higher processors. The scanner communicates over the DeviceNet network to:

- Read inputs and write outputs
- Download configuration data
- Monitor operational status

The scanner communicates with the SLC processor to exchange I/O data. Data includes device I/O data, status information, and configuration data. A single scanner can communicate with up to 63 nodes. The SLC system can support multiple scanners.



1761-NET-DNI DeviceNet Interface Device

The DNI takes the DF1 full-duplex commands, wraps them in the DeviceNet protocol and sends them to the target DNI. The target DNI removes the DeviceNet information and passes the DF1 command to the end device (Also acts as an interface for DF1 devices to the DeviceNet network).

This capability works between controllers, between PCs and controllers, and for program up/downloading. I/O and data messages are prioritized, which minimizes

I/O determinism problems typically encountered on networks that support I/O and messaging simultaneously.

Features

- Mixes high-speed local control with distributed DeviceNet I/O
- Peer-to-peer messaging between MicroLogix, SLC 5/03, 5/04, 5/05, PLC-5s, PCs and other devices
- Programming and online monitoring over the Device Net network
- With a DNI connected to a modem, you can dial in to any other DNI-Controller combination on DeviceNet



Data Highway Plus



The Data Highway Plus (DH+) network is a local-area network designed to support remote programming and data acquisition for factory-floor applications. You can also use DH+ communication modules to implement a peer-to-peer network.

You can use a DH+ network for data transfer to other PLC-5 controllers or high-level computers and as a link for programming multiple PLC-5 controllers. A PLC-5 programmable controller can communicate over a DH+ network with other controllers and with a workstation.

The DH+ network supports daisy chain and trunkline-dropline configurations. The number of supported devices on a DH+ link and the length of the cable depends on the communication rate.

Data Highway Plus connectivity for the SLC 500 is provided by the SLC 5/04 processor; see page 9 for more details.

DH-485 Network

The DH-485 communication network allows devices on the plant floor to share information. Via the network, application programs can:

- Monitor process and device parameters and status, including fault and alarm detection
- Perform data acquisition
- Perform supervisory control functions
- Upload/download PLC programs over the network

The DH-485 network offers:

- Interconnection of up to 32 nodes
- Multi-master capability
- Slave devices
- Token-passing access control
- The ability to add or remove nodes without disruption of the network

1747-KE DH-485/RS-232C Interface Module

The DH-485/RS-232C Interface Module provides a bridge between the DH-485 communication network and RS-232 using Allen-Bradley's DF1 communication protocol. When used in a SLC 500 chassis with a modem, you can:

- remotely program and troubleshoot any single SLC 500 processor
- remotely communicate to a DH-485 network of SLC 500 processors
- remotely collect data directly from the data table of any SLC 500 processor
- use the SLC 500 as a remote terminal unit

1747-AIC Isolated Link Coupler

SLC 500 programmable controllers communicate across an embedded DH-485 network for program support and monitoring. The following products provide networking options for the SLC 500 programmable controllers: 1747-PIC Interface Converter, 1747-AIC, and 1761-NET-AIC Advanced Interface Converter. The Isolated Link Coupler provides an electrically isolated network connection for an SLC 500 controller. One coupler is required at each DH-485 network drop. The coupler includes a 304.8 mm (12 in.) cable for connection to the programmable controller. Note that a maximum of 32 devices can be connected to the network.

1761-NET-AIC Advanced Interface Converter



This device is an isolated RS-232 to RS-485 converter. It allows two RS-232 devices (SLC 5/03, SLC 5/04, SLC 5/05; MicroLogix 1000, 1200, and 1500; DTAM Micro; PanelView 500 and 900) to connect to the DH-485 network. The AIC+ can be DIN-rail or panel mounted and is industrially hardened (UL, CSA, CE).

Universal Remote I/O

The strength and versatility of the Universal Remote I/O network comes from the breadth of products it supports. In addition to 1746 I/O, the Universal Remote I/O network supports many Allen-Bradley and third-party devices.

Typical applications range from simple I/O links with controllers and I/O, to links with a variety of other devices. You connect devices through remote I/O adapter modules or built-in remote I/O adapters. Using the Universal Remote I/O network instead of direct-wiring a device over a long distance to a local I/O chassis helps reduce installation, start-up, and maintenance costs by placing the I/O closer to the sensors and actuators.

Some devices support "Pass-Through," which lets you configure devices remotely from a Ethernet, DH+, or DH-485/DF1 network to a Universal Remote I/O network. The latest SLC 500 operating systems (1747-OS310, 1747-OS410, and 1747-OS510) support block transfer instructions for faster reading and writing of I/O data. See "Operating System Upgrade Kits" on page 11 if you'd like to add this feature to your existing SLC 5/03 or higher processor.

Universal Remote I/O connectivity for the SLC 500 is provided by the following interfaces:

1747-SN Remote I/O Scanner

The Remote I/O Scanner provides high-speed remote communication between an SLC processor and Allen-Bradley operator interface and control devices. The scanner provides connectivity of your SLC 5/02 or higher processor to devices such as RediPANEL, DL40 Dataliner, PanelView, 1791 Block I/O, Allen-Bradley drives, 1746 I/O, 1771 I/O, and Flex I/O devices.

The Series B scanner supports block transfer of up to 64 words of data.

Features

- Selectable baud rates — Provide noise immunity over various cable distances.
- RIO link cable length up to 3050m (10,000 ft.) — Allows for distribution of devices over a wide physical area.
- Supports connection of up to 16 devices in normal mode, or up to 32 devices in complementary mode.
- Block transfers to RIO adapter devices — Sends large amounts of data to RIO devices without effecting total system throughput.
- Supports remote I/O passthrough — Allows you to download and change applications in PanelViews and Dataliners.



1747-BSN Backup Remote I/O Scanner

The 1747-BSN back-up scanner module allows for a redundant SLC-500 processors (SLC-5/02 or greater) system. The BSN allows for the backup of remote I/O and network communications. This module is designed for critical applications where unexpected shutdowns can be potentially hazardous and costly. This SLC module contains the full complement of both Remote I/O scanner and back up communication features.

A pair of 1747-BSN modules and SLC-500 processors, primary and secondary, operate in a redundant (asynchronous data transfer) configuration with Remote I/O. The primary processor controls the I/O, while the secondary processor receives the same remote input data. The BSN modules communicate over a HSSL (High Speed Serial Link) to keep the secondary processor continuously updated with your retentive data. In the event of a primary processor failure the secondary processor takes over control of the system. The 1747-BSN module offers you virtually uninterrupted operation capability for your process.

1747-BSN Features

- Backup of one Remote I/O or DH+ network per complimentary BSN module pair.
- Backup of one RS232/485 communications per complimentary BSN module pair. This allows customer HMIs on channel 0 to automatically transfer to the primary processor.
- Transfer of up to 2KW of customer retentive data per BSN.
- Repair primary system fault during secondary back-up system operation
- System hardware isolation guarantees primary system issues do not affect other systems
- Remote programming capability of secondary processor on DH+ (SLC-5/04 only)
- Minimal user program impact
- Back up system diagnostic information

1747-ASB Remote I/O Adapter Module

The Remote I/O Adapter module is a single-slot, RIO communication link module. It occupies the first slot (slot 0) of a 1746 remote chassis, where the SLC processor normally resides. The ASB module acts as a gateway between an SLC 500 remote I/O scanner and the I/O modules in the 1747-ASB remote and expansion chassis. The ASB module is compatible with all Allen-Bradley RIO scanners.

Features

- Supports 1/2-slot, 1-slot, and 2-slot addressing — Provides efficient image utilization by allowing you to assign the amount of space required.
- Monitor three 7-segment displays - Provides status information and troubleshooting.

1747-DCM Direct Communication Module

The Direct Communication Module (DCM) links the SLC 500 controller to the Allen-Bradley PLC for distributed processing. The DCM acts as a remote I/O adapter on a remote I/O link. Information is transferred between a local PLC or SLC scanner and a remote 1747-DCM module during each remote I/O scan. The number of DCMs that a scanner can supervise depends on the number of chassis's the scanner supports and the chassis size of the DCM. The SLC 500 modular controllers support multiple DCMs. An important distinction between a DCM module and an ASB is that a DCM is placed in a chassis with a processor and it does not scan any I/O in the chassis as an ASB does.

Serial Network

The SLC 5/03, 5/04, and 5/05 processors (see pages 8-10) have a serial port which is configurable for RS-232, RS-423, or RS-422A-compatible serial communication. Use the serial port to connect devices that:

- Communicate using the DF1 protocol, such as modems, communication modules, programming workstations, or other Encompass partner devices.
- Send and receive ASCII characters, such as ASCII terminals, bar-code readers, and printers.

When configured for system mode, the serial port supports the DF1 protocol. Use system mode to communicate with others devices on the serial link. You can select a DF1 mode:

- Point to point: communication between a SLC 500 controller and other DF1-compatible devices. In point-to-point mode, the SLC 500 controller uses DF1 full-duplex protocol.
- DF1 master: control of polling and message transmission between the master and each remote node. In master mode, the SLC 500 controller uses DF1 half-duplex polled protocol.
- DF1 slave: using the controller as a slave station in a master/slave serial network. In slave mode, the SLC 500 controller uses DF1 half-duplex protocol.

The serial port (in system mode) also supports supervisory control and data acquisition (SCADA) applications. SCADA systems let you monitor and control remote functions and processes using serial communication links between master and slave locations.

When configured for user mode, the serial port supports ASCII devices. Use the SLC 500 ASCII instructions to send and receive information from these devices.

Power Supplies

Allen-Bradley offers seven different power supplies: three ac and four dc. The ac supplies can be configured to operate using 120 or 240V ac.



When configuring an SLC modular system, each chassis requires a power supply to provide power to the processor and I/O slots. Careful system configuration results in the best performance. Excessive loading of the power supply outputs can cause a power supply shutdown or premature failure. You should consider future system expansion when selecting a power supply.

Features

- All power supplies have an LED that illuminates when the power supply is functioning properly — Saves troubleshooting time.
- Power supplies are designed to withstand brief power losses — Power loss does not affect system operation for a period between 20 milliseconds and 3 seconds, depending on the load.
- The ac power supplies have a jumper wire for easily selecting 120 or 240V ac — No special wiring is required.

Selection Chart

Description	1746-P1	1746-P2	1746-P3	
Line Voltage	85 to 132V ac 170 to 265V ac (47to 63 Hz)	85 to 132V ac 170 to 265V ac (47to 63 Hz)	19.2 to 28.8V dc	
Internal Current Capacity	2A at 5V dc 0.46A at 24V dc	5A at 5V dc 0.96A at 24V dc	3.6A at 5V dc 0.87A at 24V dc	
Typical Line Power Requirement	135 VA	180 VA	90 VA	
Maximum Inrush Current	20A	20A	20A	
Fuse Protection	1746-F1	1746-F2	1746-F3	
24V dc User Power Current Capacity	200 mA	200 mA	Not Applicable	
24V dc User Power Voltage Range	18-30V dc	18-30V dc	Not Applicable	
Ambient Operating Temperature Rating	0°C to +60°C (+32°F to +140°F) (Current capacity de-rated 5% above +55°C)			
Wiring	two 14 AWG wires per terminal (maximum)			
Description	1746-P4	1747-P5	1747-P6	1747-P7
Line Voltage	85 to 132V ac 170 to 265V ac (47to 63 Hz)	90 to 140V dc	30 to 60V dc	10 to 30V dc
Internal Current Capacity	10.0A at 5V dc 2.88A at 24V dc	5A at 5V dc 0.96A at 24V dc	5A at 5V dc 0.96A at 24V dc	12V dc input: • 2A at 5V dc • 0.46A at 24V dc 24V dc input: • 3.6A at 5V dc • 0.87A at 24V dc
Typical Line Power Requirement	240 VA	85 VA	100 VA	50 VA at 12V dc 75 VA at 24V dc
Maximum Inrush Current	45A	20A	20A	20 A
Fuse Protection	Non-replaceable fuse is soldered in place.			
24V dc User Power Current Capacity	1A	200 mA	200 mA	Not Applicable
24V dc User Power Voltage Range	20.4 to 27.6V dc	18 to 30V dc	18 to 30V dc	Not Applicable
Ambient Operating Temperature Rating	0°C to +60°C (+32°F to +140°F) no derating	0°C to +60°C (+32°F to +140°F) (Current capacity derated 5% above +55°C)		
Wiring	two 14 AWG wires per terminal (maximum)			

IMPORTANT

For the 1746-P4, the combination of all output power (5V dc backplane + 24V dc backplane + 24V dc user power) cannot exceed 70 Watts.

Chassis

The chassis houses the processor and the I/O modules. There are four sizes of chassis that you can choose: 4-slot, 7-slot, 10-slot, and 13-slot.

Each chassis must have a power supply. The power supply mounts on the left side of the chassis. The first slot of the first chassis is reserved for the SLC processor or adapter module (1747-ASB, or 1747-ACN15 or -ACNR15).

All components easily slide into the chassis along guides formed in the chassis. No tools are required to insert or remove the processor or I/O modules.

Chassis can also be connected together to form a system (3 chassis maximum) by using one of the chassis interconnect cables.



Selection Chart

Catalog Number	Description
1746-A4	4-Slot Chassis
1746-A7	7-Slot Chassis
1746-A10	10-Slot Chassis
1746-A13	13-Slot Chassis

Chassis Interconnect Cables

Catalog Number	Description
1746-C7	0.15m (6 in.) Chassis Interconnect Cable — This ribbon cable is used when linking modular hardware style chassis up to 0.15m (6 in.) apart in an enclosure.
1746-C9	0.91m (36 in.) Chassis Interconnect Cable — This cable is used when linking modular hardware style chassis from 0.15m (6 in.) up to 0.91m (36 in.) apart in an enclosure.
1746-C16	1.27m (50 in.) Chassis Interconnect Cable — This cable is used when linking modular hardware style chassis from 0.91m (36 in.) up to 1.27m (50 in.) apart in an enclosure.

Card Slot Filler

Use the 1746-N2 card slot filler to protect any unused slots on the chassis.

Programming Options

The following sections describe programming options available for the SLC 500. You can create and edit ladder programs using a personal computer or the 1747-PT1 Hand-Held Terminal (HHT, for SLC 5/01 and 5/02 processors only).



RSLogix 500™ Programming Software

The RSLogix 500 ladder logic programming package helps you maximize performance, save project development time, and improve productivity. This product has been developed to operate on Microsoft's 32-bit, Windows 95®, Windows 98® and Windows NT™ operating systems. Supporting Allen-Bradley's SLC 500 and MicroLogix families of processors, RSLogix 500 was the first PLC programming software to offer unbeatable productivity with an industry-leading user interface.



RSLogix 500 programming packages are compatible with programs created with Rockwell Software's DOS-based programming packages for the SLC 500 and MicroLogix families of processors, making program maintenance across hardware platforms convenient and easy.

Flexible, Easy-to-Use Editors

Flexible program editors let you create application programs without worrying about getting the syntax correct as you create your program. A Project Verifier builds a list of errors that you can navigate to make corrections at your convenience.

Powerful online editing features let you modify your application program while the process is still operating. The Test Edits feature allows you to test the operation of your modification before it becomes a permanent part of the application program. Online and offline editing sessions are limited only by the amount of available RAM.

Projects developed with Rockwell Software's DOS programming packages, SLC-500 and MicroLogix A.I. Series, APS and MPS, can be moved to the RSLogix environment simply by opening the existing project with the appropriate RSLogix package. Conversely, it is just as easy to move a project developed with RSLogix to any of the DOS programming packages.

Drag-and-drop editing lets you quickly move or copy instructions from rung to rung within a project, rungs from one subroutine or project to another, or data table elements from one data file to another.

Context menus for common software tools are quickly accessible by clicking the right mouse button on addresses, symbols, instructions, rungs, or other application objects. This convenience provides you with all the necessary functionality to accomplish a task within a single menu. This is a time-saving feature because you don't have to remember the placement of functionality options in the menu bar.

Point-and-Click I/O Configuration



The easy-to-use I/O Configurator lets you click or drag-and-drop a module from an all-inclusive list to assign it a slot in your configuration. Advanced configuration, required for specialty and analog modules, is easily accessible. Convenient forms speed entry of configuration data. An I/O auto configuration feature is also available.

Powerful Database Editor

Use the Symbol Group Editor to build and classify groups of symbols so that you can easily select portions of your recorded documentation to be used from project to project.

Use the Symbol Picker list to easily address instructions in your ladder logic by clicking addresses or symbols to assign them to your ladder instructions. Stop worrying about restricting the amount of the descriptive text that accompanies the ladder logic. Your documentation is only limited by the size of your hard disk.



Export your database to Comma-Separated-Value (CSV) format for use with many of today's popular spreadsheet programs to take advantage some of their features. Once finished, simply import the CSV file into RSLogix.

Diagnostics and Troubleshooting Tools



Quickly locate the specific area in the application that is causing a problem with *Advanced Diagnostics*. Diagnose the interaction of output instructions within a section of your program by viewing them at the same time.

Simultaneously examine the status of bits, timers, counters, inputs, and outputs all in one window with the *Custom Data Monitor*. Each application project you create can have its own *Custom Data Monitor* window.

Easily review status bit setting specific to your application programming including *Scan Time* information, *Math Register* information, Interrupt settings and more with the tabbed Status displays.

Assistance on Demand

If you do not understand an RSLogix function, or if you have a question about a processor instruction, you can access the comprehensive online Help system and PLC instruction reference. The Help system even includes step-by-step instructions to lead you through many common activities.

Technical Specifications

- IBM compatible 486/66 MHz or greater (Pentium recommended)
- Microsoft Windows 95 or Windows NT (Version 4)
- 32 MB of RAM (64 MB recommended)
- 10 MB of hard disk space for RSLogix 500 (or more based on application requirements)
- 16-color VGA Graphics Adapter 640 x 480 or greater resolution (256-color 800 x 600 optimal)
- Products require the use of RSLinx Lite. RSLinx Lite and WINTelligent LINX Lite are included with RSLogix 500

Selection Chart

Catalog Number	Description
9324-RL0300ENE	RSLogix 500 Programming for the SLC 500 and MicroLogix Families on CD-ROM. Includes RSLinx Lite and WINTelligent LINX Lite.
9324-RL0100ENE	RSLogix 500 Starter programming for the SLC 500 and MicroLogix Families on CD-ROM. This package is a functionally limited version of RSLogix 500.

For the very latest on Rockwell Software product development, visit our web site on the Internet at <http://www.software.rockwell.com>.

1747-PT1 Hand-Held Terminal and 1747-PTA1E Programming Memory Pak



The Hand-Held Terminal (HHT) v2.03 is a powerful portable programming platform used to configure the SLC 500 Fixed, SLC 5/01, and the SLC 5/02 processors. It is used to enter or modify an application program, monitor the execution of the application program in real-time, or troubleshoot an application program.

The programming memory pak is interchangeable and available in four languages. When used with the memory pak (v2.03), the HHT can be used to program the SLC 5/02 processor as well as connect to the DH-485 network. The HHT does not support all ladder functions supported by the programming software

Features

- Rugged construction — Designed for a variety of industrial environments.
- Menu-driven firmware — Displays step-by-step directions.
- LCD display — Shows up to five rungs of ladder logic at one time.
- Network diagnostics — Checks the operation of the DH-485 network (v2.03).
- ZOOM function — Displays detailed instruction information.
- Formatted display — Displays PID and MSG instructions (v2.03).

Specifications

Description	Specification
Display	8 line x 40 character super-twist nematic LCD
Keyboard	30 keys
Operating Power	0.105A (max.) at 24 VDC
Communication	DH485
Environmental Conditions	Operating Temperature: 0°C to +40°C (+32°F to +104°F) Storage Temperature: -20°C to +65°C (-4°F to +149°F)

1747-PIC Interface Converter

The 1747-PIC Interface Converter changes RS-232 signal levels from your personal computer to RS-485 signal levels for the SLC 500 controller. The converter includes a 279.4 mm (11 in.) 25-pin ribbon cable for connection to the computer and a cable (Catalog Number 1746-C10) for connection to the SLC 500 controller.

SLC Programming Instruction Set

The following table shows the SLC 500 programming instruction set listed within their functional groups.

The latest SLC 500 operating systems (1747-OS310, 1747-OS410, and

- 1747-OS510) support eight new instructions. See “Operating System Upgrade Kits” on page 11 if you’d like to upgrade your existing SLC 5/03 or higher processor to use these new instructions. The new instructions are:
 - BTR - Block Transfer Read
 - BTW - Block Transfer Write
 - FBC - File Bit Comparison
 - DDT - Diagnostic Detect
 - RHC - Read High-Speed Clock
 - TDF - Compute Time Difference
 - ENC - Encode 1-of-16 to 4
 - RMP - Ramp

Functional Group	Description
Relay-Type (Bit)	The relay-type (bit) instructions monitor and control the status of bits. XIC, XIO, OTE, OTL, OTU, OSR
Timer and Counter	The timer and counter instructions control operations based on time or the number of events. TON, TOF, CTU, CTD, RTO, RES, RHC, TDF
Compare	The compare instructions compare values by using an expression or a specific compare instruction. EQU, NEQ, LES, LEQ, GRT, GEQ, MEQ; SLC 5/02 and higher: LIM
Compute	The compute instructions evaluate arithmetic operations using an expression or a specific arithmetic instruction. ADD, SUB, MUL, DIV, DDV, CLR, NEG; SLC 5/02 and higher: SQR, SCL; SLC 5/03 and higher: SCP, ABS, CPT, SWP, ASN, ACS, ATN, COS, LN, LOG, SIN, TAN, XPY, RMP
Logical	The logical instructions perform logical operations on bits. AND, OR, XOR, NOT
Conversion	The conversion instructions perform conversions between integer and BCD values, and radian and degree values. TOD, FRD, DCD; SLC 5/03 and higher: DEG, RAD, ENC
Move	The move instructions modify and move bits. MOV, MVM
File	The file instructions perform operations on file data. COP, FLL, BSL, BSR; SLC 5/02 and higher: FFL, FFU, LFL, LFU, FBC, DDT
Sequencer	The sequencer instructions monitor consistent and repeatable operations. SQO, SQC; SLC 5/02 and higher: SQL
Program Control	The program flow instructions change the flow of ladder program execution. JMP, LBL, JSR, SBR, RET, MCR, TND, SUS, IIM, IOM, END; SLC 5/02 and higher: REF
User Interrupt	The user interrupt instructions allow you to interrupt your program based on defined events. SLC 5/02 and higher: STD, STE, STS, IID, IIE, RPI, INT
Process Control	The process control instruction provides closed-loop control. SLC 5/02 and higher: PID
Communications	The communication instructions read or write data to another station. SLC 5/02 and higher only: MSG, SVC, BTR, BTW
ASCII	The ASCII instructions read, write, compare, and convert ASCII strings. SLC 5/03 and higher only: ABL, ACB, ACI, ACL, ACN, AEX, AHL, AIC, ARD, ARL, ASC, ASR, AWA, AWT

7 Steps to Successfully Configuring an SLC 500 System

Step 1: Review the Family of Products and Determine Your Communication Requirements

The SLC family has a wide variety of products offers some of the best communication options available for a small PLC. Take a couple of minutes to review the SLC product offerings.

Step 2: Choose a CPU

The SLC family offers five designs of CPUs, the SLC 5/01, 5/02, 5/03, 5/04, and 5/05. Please take time to understand the specifications of each CPU. Consider the system's needs for communications, memory, speed, and functionality.

Step 3: Choose the I/O Modules

There are over 40 I/O modules available for the SLC system. It is important to review the detailed specifications for all modules that will be used in your system.

Step 4: Choose the I/O Configuration

It is important to understand how the I/O system can be configured. The flexibility of the SLC offers several different types of configurations, such as: Local I/O, Expansion I/O, Remote I/O.

Step 5: Choose Necessary Accessories

Step 6: Choose Your Power Supply

After you have chosen your system components, total your 5V dc and 24V dc currents and choose the appropriate chassis power supply. This is an extremely important step to help ensure proper system operation. See "Power Supply Selection Example" on page 51 for the power supply selection procedure.

Step 7: Call your local Allen-Bradley representative

Power Supply Selection Example

Select a power supply for chassis 1 and chassis 2 in the control system below. The example worksheet for this system is shown on page 52. A blank worksheet is shown on page 53.

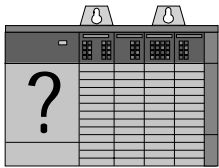
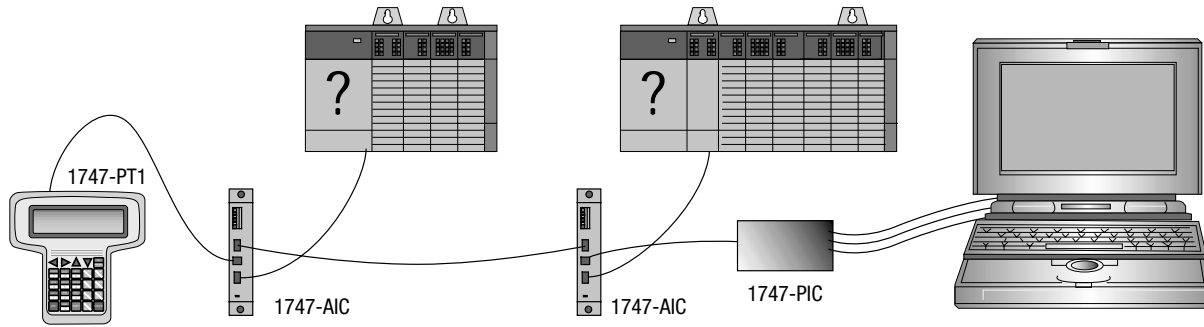

Slot Numbers	Description	Catalog Number	Power Supply at 5V dc (Amps)	Power Supply at 24V (Amps)
0	Processor Unit	1747-L511	0.35	0.105
1	Input Module	1747-IV8	0.05	NA
2	Transistor Output Module	1746-OB8	0.135	NA
3	Triac Output Module	1746-OA16	0.37	NA
Peripheral Device	Hand-Held Terminal	1747-PT1	NA	NA
Peripheral Device	Isolated Link Coupler	1747-AIC	NA	NA
Total Current:			0.905	0.190 ⁽¹⁾

(1) Power Supply 1746-P1 is sufficient for Chassis #1. the "Internal Current Capacity" for this power supply is 2 Amps at 5V dc; 0.46 Amps at 24V dc.

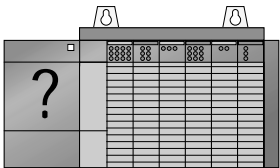

Slot Numbers	Description	Catalog Number	Power Supply at 5V dc (Amps)	Power Supply at 24V (Amps)
0	Processor Unit	1747-L514	0.35	0.105
1	Output Module	1746-OW16	0.17	0.180
2	Combination Module	1746-IO12	0.09	.07
3,4,5,6	Analog Output Modules	1746-NO4I	0.22 (4 x 0.055)	0.780 (4 x 0.195)
Peripheral Device	Isolated Link Coupler	1747-AIC	NA	0.085
Peripheral Device	Interface Converter	1746-PIC	NA	NA
Total Current:			0.83	1.22 ⁽¹⁾

(1) Power Supply 1746-P4 is sufficient for Chassis #2. The "Internal Current Capacity" for this power supply is 10 Amps at 5V dc; not to exceed 70 Watts. (This configuration = 33.43 Watts, i.e., [5V x 0.083] + [24V x 1.22A] = 33.43W)

Example Worksheet for Selecting 1746 Power Supplies for the Example System

For a detailed list of device load currents, see page 54. Remember to consider future system expansion when selecting a power supply.

Procedure									
1. For each slot of the chassis that contains a module, list the slot number, the catalog number of the module, and its 5V and 24V maximum currents. Also include the power consumption of any peripheral devices that may be connected to the processor other than a DTAM, HHT, or PIC—the power consumption of these devices is accounted for in the power consumption of the processor.									
Chassis Number		1	Maximum Currents		Chassis Number		2	Maximum Currents	
Slot Number		Catalog Number	at 5V dc	at 24V dc	Slot Number		Catalog Number	at 5V dc	at 24V dc
Slot	0	1747-L511	0.350A	0.105A	Slot	0	1747-L514	0.350A	0.105A
Slot	1	1746-IV8	0.050A	—	Slot	1	1746-OW16	0.170A	0.180A
Slot	2	1746-OB8	0.135A	—	Slot	2	1746-N04I	0.055A	0.195A
Slot	3	1746-OA16	0.370A	—	Slot	3	1746-N04I	0.055A	0.195A
Slot					Slot	4	1746-N04I	0.055A	0.195A
Slot					Slot	5	1746-N04I	0.055A	0.195A
Slot					Slot	6	1746-IO12	0.090A	0.070A
Slot					Slot				
Peripheral Device		A/C	—	0.085A	Peripheral Device		A/C	—	0.085A
Peripheral Device					Peripheral Device				
2. Add the loading currents of all the system devices at 5 and 24V dc to determine the Total Current.			0.905A	0.190A	2. Add the loading currents of all the system devices at 5 and 24V dc to determine the Total Current.			0.830A	1.220A
3. For 1746-P4 power supplies, calculate the total power consumption of all system devices. If you are not using a 1746-P4, go to step 4.									
Current		Multiply by	= Watts	Current		Multiply by	= Watts		
Total Current at 5V dc	0.905A	5V	4.525W	Total Current at 5V dc	0.830A	5V	4.15W		
Total Current at 24V dc	0.190A	24V	4.56W	Total Current at 24V dc	1.220A	24V	29.28W		
User Current at 24V dc	0.500A	24V	12.00W	User Current at 24V dc	0.500A	24V	12.00W		
Add the Watts values to determine Total Power (cannot exceed 70 Watts)			21.085W	Add the Watts values to determine Total Power (cannot exceed 70 Watts)			45.43W		
4. Choose the power supply from the list of catalog numbers shown below. Compare the Total Current required for the chassis with the Internal Current capacity of the power supplies. Be sure that the Total Current consumption for the chassis is less than the Internal Current Capacity for the power supply, for both 5V and 24V loads.									
Catalog Number		Internal Current Capacity		Catalog Number		Internal Current Capacity			
		at 5V dc	at 24V dc			at 5V dc	at 24V dc		
1746-P1		2.0A	0.46A	1746-P1		2.0A	0.46A		
1746-P2		5.0A	0.96A	1746-P2		5.0A	0.96A		
1746-P3		3.6A	0.87A	1746-P3		3.6A	0.87A		
1746-P4 (see step 3)		10.0A	2.88A	1746-P4 (see step 3)		10.0A	2.88A		
1746-P5		5.0A	0.96A	1746-P5		5.0A	0.96A		
1746-P6				1746-P6					
1746-P7				1746-P7					
Required Power Supply		1746-P1		Required Power Supply		1746-P4			

Blank Worksheet for Selecting 1746 Power Supplies

If you have a multiple chassis system, make copies of the Worksheet for Selecting a Power Supply.

For a detailed list of device load currents, see page 54. Remember to consider future system expansion when selecting a power supply.

Procedure							
1. For each slot of the chassis that contains a module, list the slot number, the catalog number of the module, and its 5V and 24V maximum currents. Also include the power consumption of any peripheral devices that may be connected to the processor other than a DTAM, HHT, or PIC—the power consumption of these devices is accounted for in the power consumption of the processor.							
Chassis Number		Maximum Currents		Chassis Number		Maximum Currents	
Slot Number	Catalog Number	at 5V dc	at 24V dc	Slot Number	Catalog Number	at 5V dc	at 24V dc
Slot				Slot			
Slot				Slot			
Slot				Slot			
Slot				Slot			
Slot				Slot			
Slot				Slot			
Slot				Slot			
Slot				Slot			
Peripheral Device				Peripheral Device			
Peripheral Device				Peripheral Device			
2. Add the loading currents of all the system devices at 5 and 24V dc to determine the Total Current.				2. Add the loading currents of all the system devices at 5 and 24V dc to determine the Total Current.			
3. For 1746-P4 power supplies, calculate the total power consumption of all system devices. If you are not using a 1746-P4, go to step 4.							
Current		Multiply by	= Watts	Current		Multiply by	= Watts
Total Current at 5V dc		5V		Total Current at 5V dc		5V	
Total Current at 24V dc		24V		Total Current at 24V dc		24V	
User Current at 24V dc		24V		User Current at 24V dc		24V	
Add the Watts values to determine Total Power (cannot exceed 70 Watts)				Add the Watts values to determine Total Power (cannot exceed 70 Watts)			
4. Choose the power supply from the list of catalog numbers shown below. Compare the Total Current required for the chassis with the Internal Current capacity of the power supplies. Be sure that the Total Current consumption for the chassis is less than the Internal Current Capacity for the power supply, for both 5V and 24V loads.							
Catalog Number		Internal Current Capacity		Catalog Number		Internal Current Capacity	
		at 5V dc	at 24V dc			at 5V dc	at 24V dc
1746-P1		2.0A	0.46A	1746-P1		2.0A	0.46A
1746-P2		5.0A	0.96A	1746-P2		5.0A	0.96A
1746-P3		3.6A	0.87A	1746-P3		3.6A	0.87A
1746-P4 (see step 3)		10.0A	2.88A	1746-P4 (see step 3)		10.0A	2.88A
1746-P5		5.0A	0.96A	1746-P5		5.0A	0.96A
1746-P6				1746-P6			
1746-P7				1746-P7			
Required Power Supply				Required Power Supply			

Power Supply Loading Reference Table

Use the table below to calculate the power supply loading and heat dissipation for each chassis in your SLC modular application. Definitions of some of the terms used in the table are provided on page 56.

Hardware Component	Catalog Numbers	Maximum Current (A)		Watts per Point	Minimum Watts	Total Watts
		at 5V dc	at 24V dc			
Processors	1747-L511	0.350	0.105	NA	1.75	1.75
	1747-L514	0.350	0.105	NA	1.75	1.75
	1747-L524	0.350	0.105	NA	1.75	1.75
	1747-L531	0.500	0.175	NA	1.75	1.75
	1747-L532	0.500	0.175	NA	2.90	2.90
	1747-L541	1.000	0.200	NA	4.00	4.00
	1747-L542	1.000	0.200	NA	4.00	4.00
	1747-L543	1.000	0.200	NA	4.00	4.00
	1747-L551	1.000	0.200	NA	4.00	4.00
	1747-L552	1.000	0.200	NA	4.00	4.00
	1747-L553	1.000	0.200	NA	4.00	4.00
Input Modules	1746-IA4	0.035	—	0.270	0.175	1.30
	1746-IA8	0.050	—	0.270	0.250	2.40
	1746-IA16	0.085	—	0.270	0.425	4.80
	1746-IB8	0.050	—	0.200	0.250	1.90
	1746-IB16	0.085	—	0.200	0.425	3.60
	1746-IB32	0.050	—	0.200	0.530	6.90
	1746-IC16	0.085	—	0.220	0.425	3.95
	1746-IG16	0.140	—	0.020	0.700	1.00
	1746-IH16	0.085	—	0.320	0.675	3.08
	1746-IM4	0.035	—	0.350	0.175	1.60
	1746-IM8	0.050	—	0.350	0.250	3.10
	1746-IM16	0.085	—	0.350	0.425	6.00
	1746-IN16	0.085	—	0.350	0.425	6.00
	1746-ITB16	0.085	—	0.200	0.425	3.625
	1746-ITV16	0.085	—	0.200	0.425	3.625
	1746-IV8	0.050	—	0.200	0.250	1.90
	1746-IV16	0.085	—	0.200	0.425	3.60
	1746-IV32 ⁽¹⁾	0.050	—	0.200	0.530	6.90
Output Modules (continued on page 54)	1746-OA8	0.185	—	1.000	0.925	9.00
	1746-OA16	0.370	—	0.462	1.850	9.30
	1746-OAP12	0.370	—	1.000	1.850	10.85
	1746-OB8	0.135	—	0.775	0.675	6.90
	1746-OB16	0.280	—	0.338	1.400	7.60
	1746-OB32 ⁽¹⁾	0.190	—	0.078	2.260	4.80
	1746-OBP8	0.135	—	0.300	0.675	3.08
	1746-OBP16	0.250	—	0.310	1.250	6.21
	1746-OB16E	0.280	—	0.338	1.400	7.60
	1746-OB32E	0.452	—	0.078	2.260	4.80

Hardware Component	Catalog Numbers	Maximum Current (A)		Watts per Point	Minimum Watts	Total Watts
		at 5V dc	at 24V dc			
Output Modules (continued from page 53)	1746-OG16	0.180	—	0.033	0.900	1.50
	1746-OV8	0.135	—	0.775	0.675	6.90
	1746-OV16	0.270	—	0.388	1.400	7.60
	1746-OV32 ⁽¹⁾	0.190	—	0.078	2.260	4.80
	1746-OVP16	0.250	—	0.310	1.250	6.21
	1746-OW4	0.045	0.045	0.133	1.310	1.90
	1746-OW8	0.085	0.090	0.138	2.590	3.70
	1746-OW16	0.170	0.180	0.033	5.170	5.70
	1746-OX8	0.085	0.090	0.825	2.590	8.60
Input and Output Modules	1746-IO4	0.030	0.025	0.270 per input pt. 0.133 per output pt.	0.750	1.60
	1746-IO8	0.060	0.045	0.270 per input pt. 0.133 per output pt.	1.380	3.00
	1746-IO12	0.090	0.070	0.270 per input pt. 0.133 per output pt.	2.130	4.60
	1746-IO12DC	0.080	0.060	0.200 per input pt. 0.133 per output pt.	1.840	3.90
Specialty Modules	1746-BAS	0.150	0.040	NA	3.750	3.800
	1746-BLM	0.110	0.085	NA		
	1746-BTM	0.110	0.085	NA		
	1746-FIO4I	0.055	0.150	NA	3.760	3.800
	1746-FIO4V	0.055	0.120	NA	3.040	3.100
	1746-HSCE	0.320	—	NA	1.600	1.600
	1746-HSCE2	0.250	—	NA		
	1746-HSRV	0.300	—	NA		
	1746-HSTP1	0.300	—	NA		
	1746-INT4	0.060	0.040	NA		
	1746-MPM	0.110	0.085	NA		
	1746-NI4	0.025	0.085	NA	2.170	2.20
	1746-NI8	0.200	0.100	NA		
	1746-NI16	0.200	0.100	NA		
	1746-NIO4I	0.055	0.145	NA	3.760	3.80
	1746-NIO4V	0.055	0.115	NA	3.040	3.10
	1746-NO4I	0.055	0.195	NA	4.960	5.00
	1746-NO4V	0.055	0.145	NA	3.780	3.80
	1746-NR4	0.050	0.050	NA	1.500	1.500
	1746-NT4	0.060	0.040	NA	0.800	0.800
1746-NT8	0.120	0.070	NA			
1746-QS	1.000	0.200	NA			
1746-QV	0.215	—	NA			

Hardware Component	Catalog Numbers	Maximum Current (A)		Watts per Point	Minimum Watts	Total Watts
		at 5V dc	at 24V dc			
Communication Modules	1747-ACN15	0.900	—	NA		
	1747-ACNR15	0.900	—	NA		
	1747-ASB	0.375	—	NA	1.875	1.875
	1747-BSN	0.800	0			
	1747-DCM	0.360	—	NA	1.800	1.800
	1747-KE	0.150	0.040(2)	NA	3.750	3.800
	1747-KFC15	0.640	0	NA	3.200	3.200
	1747-SCNR	0.800	0.090	NA		
	1747-SDN	1.200	—	NA		
	1747-SN	0.900	—	NA	4.500	4.500
Peripheral Devices	1747-AIC	0	0.085	NA	2.000	2.000
	1747-DTAM	0	(3)	NA	2.500	2.500
	1747-PIC	0	(3)	NA	2.000	2.000
	1747-PSD	NA	NA	NA	NA	NA
	1747-PT1 Series A and B	0	(3)	NA	2.500	2.500
	1761-NET-AIC	0.350	0			

(1) Power supply loading for Series D and later modules.

(2) When using the BAS or KE modules to supply power to an AIC draws its power through the module. Add 0.085A (the current loading for the AIC) to the BAS or KE module's power supply loading value at 24V dc.

(3) The 24V dc loading values of the HHT, PIC, and DTAM are included in the 24V dc loading value of the processor.

(4) Current for the 1761-NET-AIC may be supplied from the controller communications port or from an external 24V dc source. No current is consumed from the controller when an external source is used.

NA = not applicable

Watts per point — the heat dissipation that can occur in each field wiring point when energized at nominal voltage.

Minimum watts — the amount of heat dissipation that can occur when there is no field power present.

Total watts — the watts per point plus the minimum watts (with all points energized).

Dimensions

4-Slot Modular Chassis

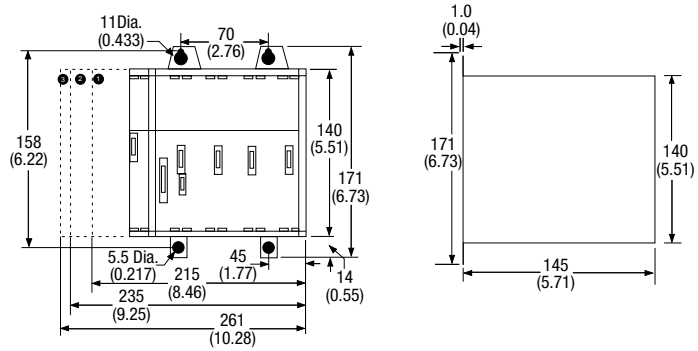

7-Slot Modular Chassis

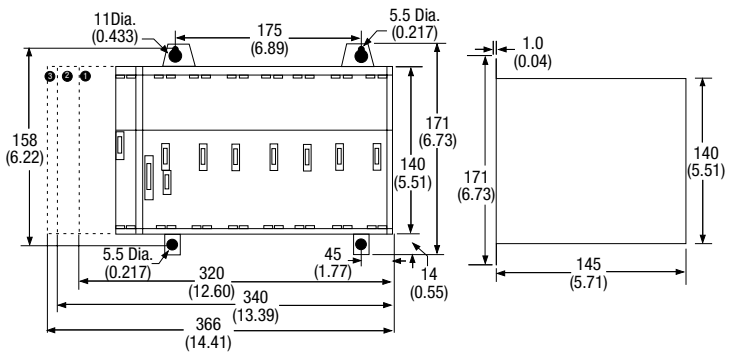

10-Slot Modular Chassis

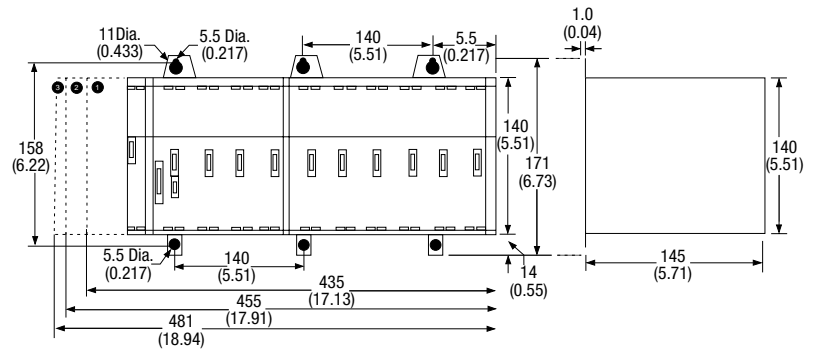

1. Dimensions for power supply catalog number 1746-P1
2. Dimensions for power supply catalog number 1746-P2, -P3, and -P5
3. Dimensions for power supply catalog number 1746-P4

13-Slot Modular Chassis

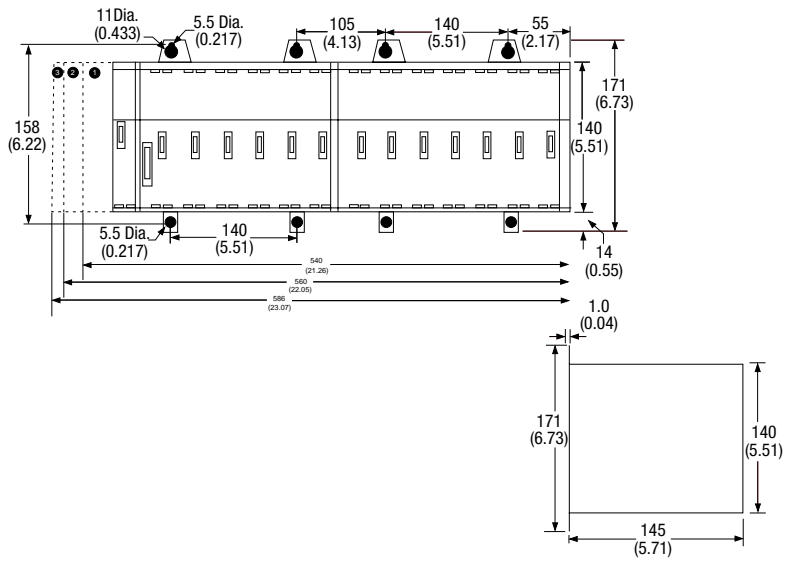

1. Dimensions for power supply catalog number 1746-P1
2. Dimensions for power supply catalog number 1746-P2, -P3, and -P5
3. Dimensions for power supply catalog number 1746-P4

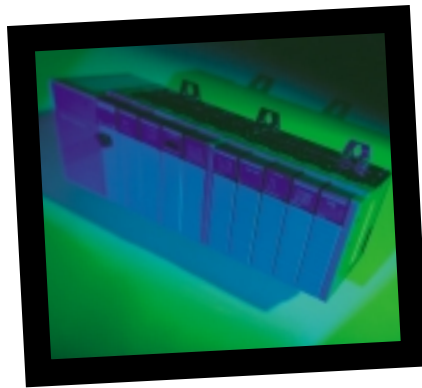

SLC 500, Data Highway Plus, MicroLogix 1000, RSLogix 500, PanelView and Dataliner are trademarks of Rockwell Automation. Ethernet is a registered trademark of Digital Equipment Corporation, Intel and Xerox Corporation. DeviceNet is a trademark of Open DeviceNet Vendor Association. Windows 95 is a registered trademark of Microsoft Corporation. Windows NT is a trademark of Microsoft Corporation.

Reach us now at www.rockwellautomation.com

Wherever you need us, Rockwell Automation brings together leading brands in industrial automation including Allen-Bradley controls, Reliance Electric power transmission products, Dodge mechanical power transmission components, and Rockwell Software. Rockwell Automation's unique, flexible approach to helping customers achieve a competitive advantage is supported by thousands of authorized partners, distributors and system integrators around the world.

Americas Headquarters, 1201 South Second Street, Milwaukee, WI 53204, USA, Tel: (1) 414 382-2000, Fax: (1) 414 382-4444
European Headquarters SA/NV, avenue Herrmann Debroux, 46, 1160 Brussels, Belgium, Tel: (32) 2 663 06 00, Fax: (32) 2 663 06 40
Asia Pacific Headquarters, 27/F Citicorp Centre, 18 Whitfield Road, Causeway Bay, Hong Kong, Tel: (852) 2887 4788, Fax: (852) 2508 1846

